

1

2

3

7

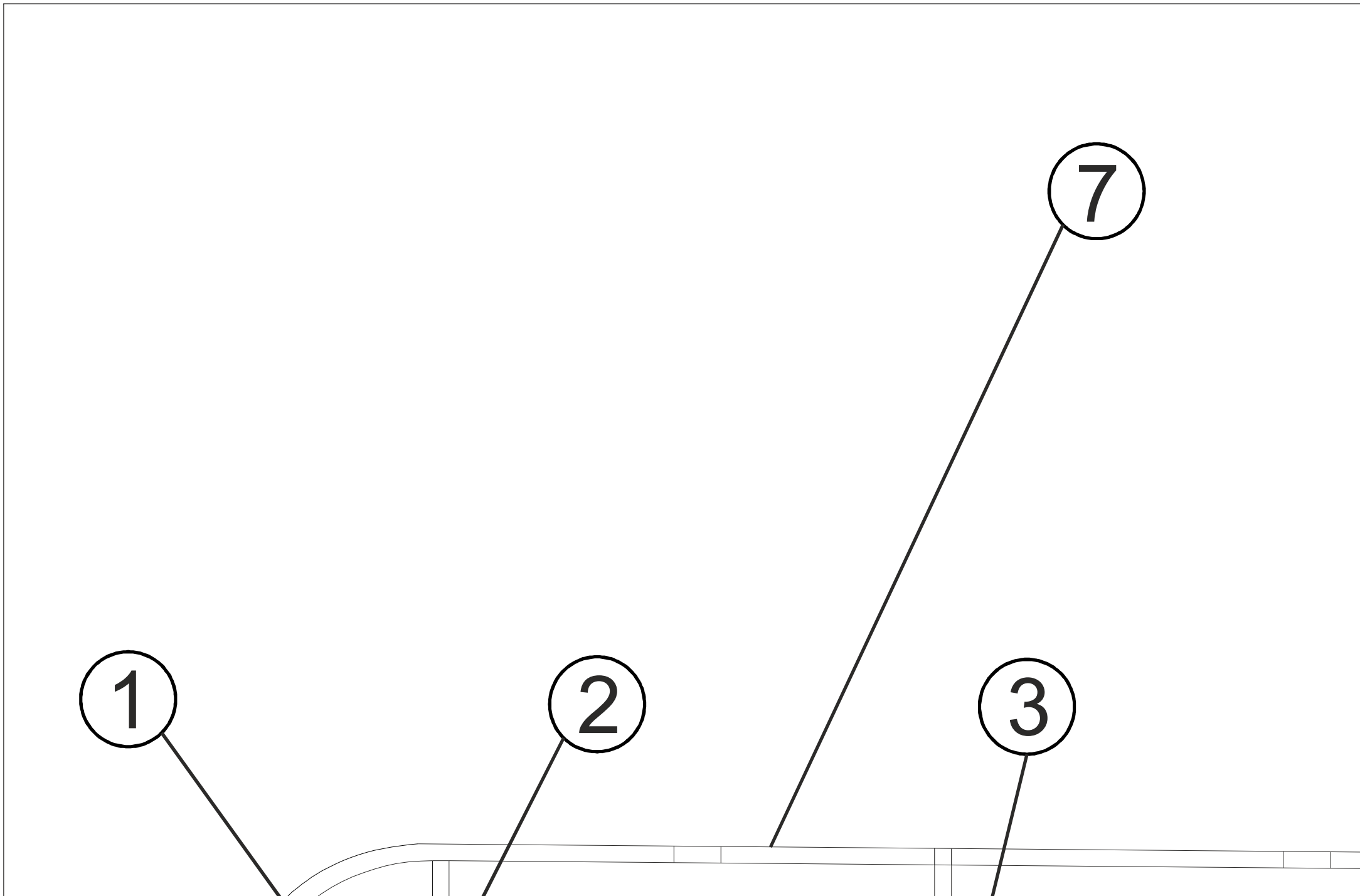

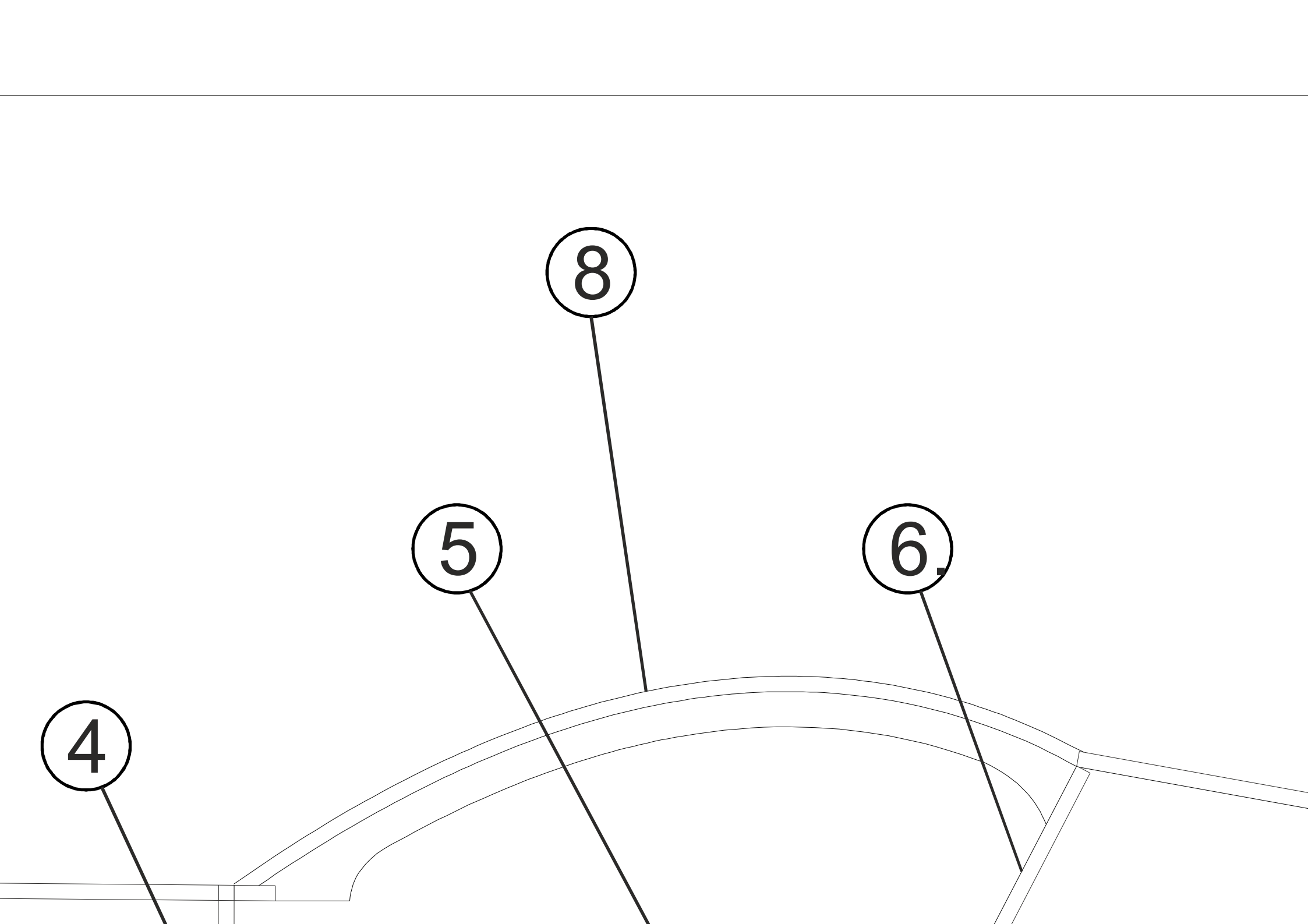

9.

10

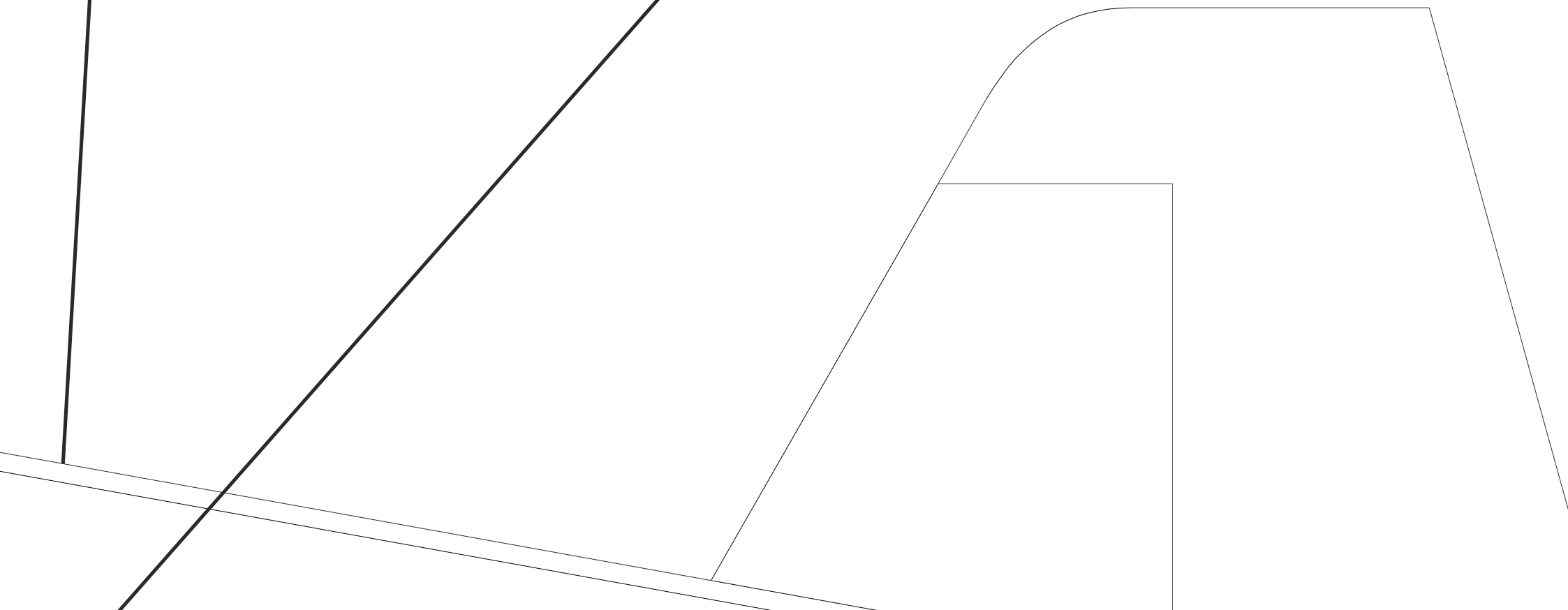

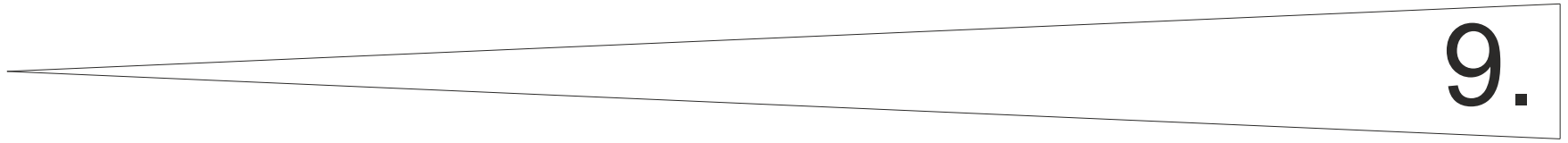

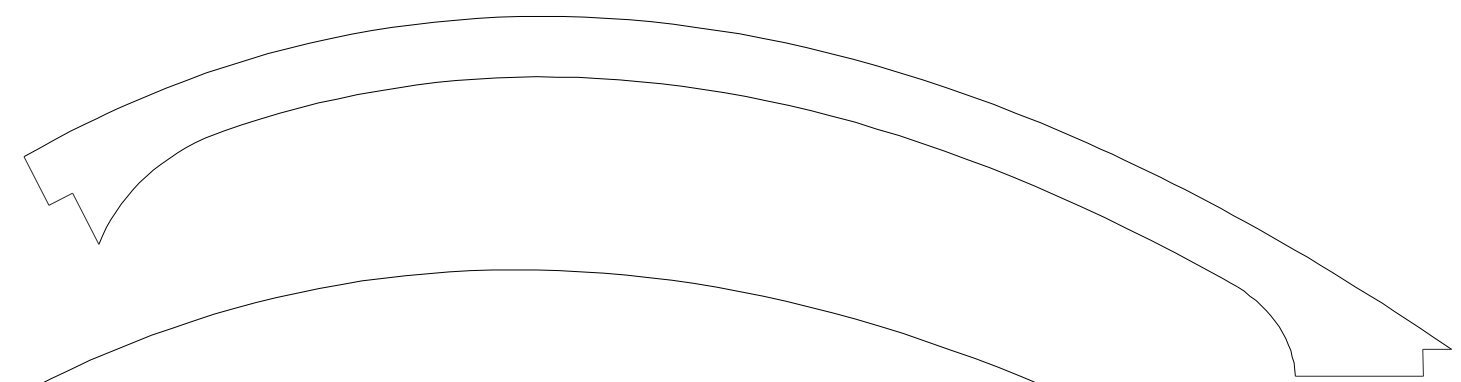
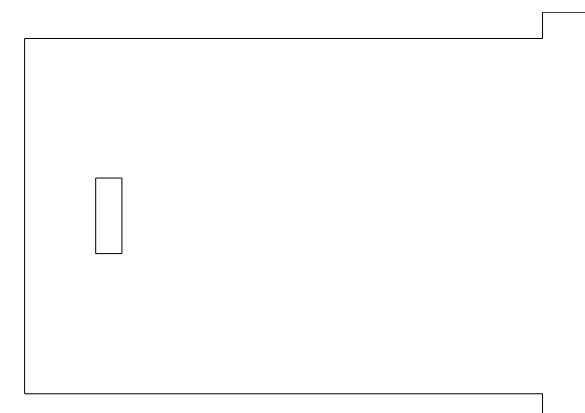
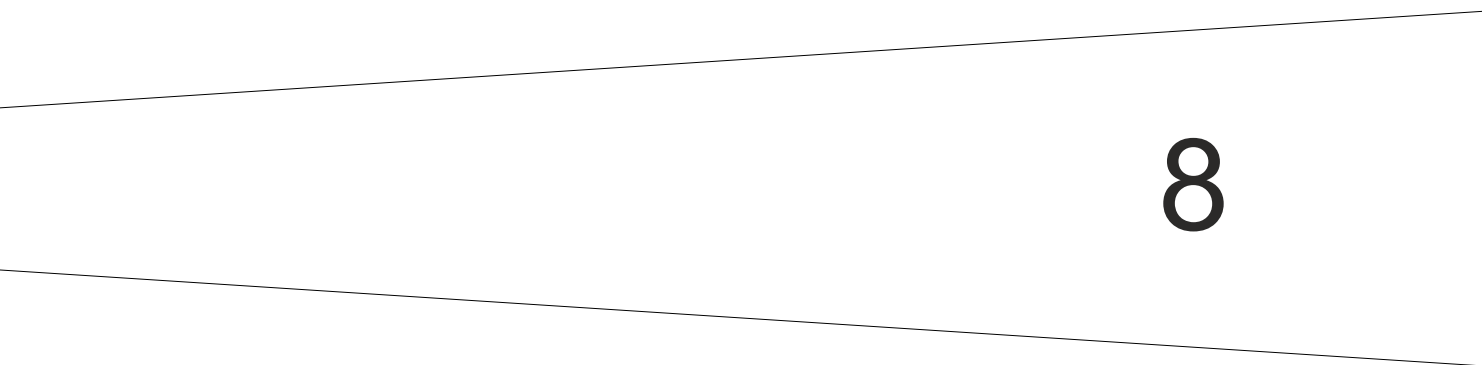

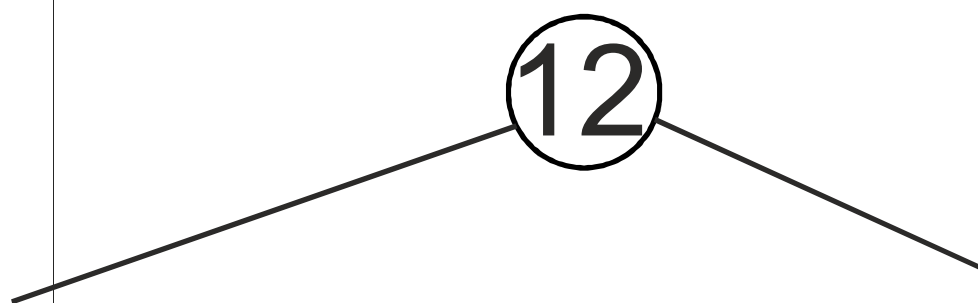
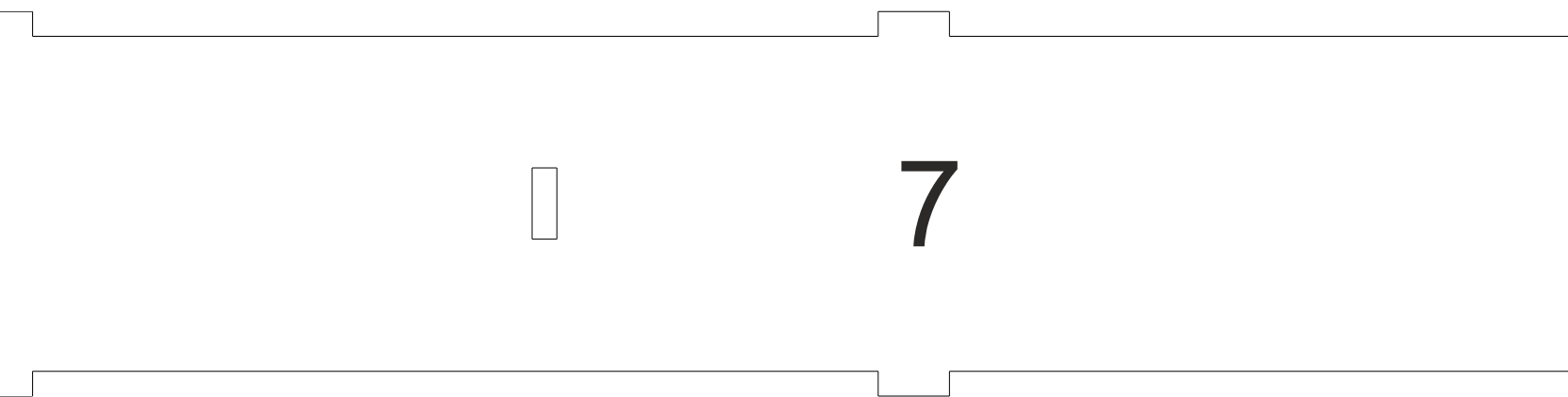



10

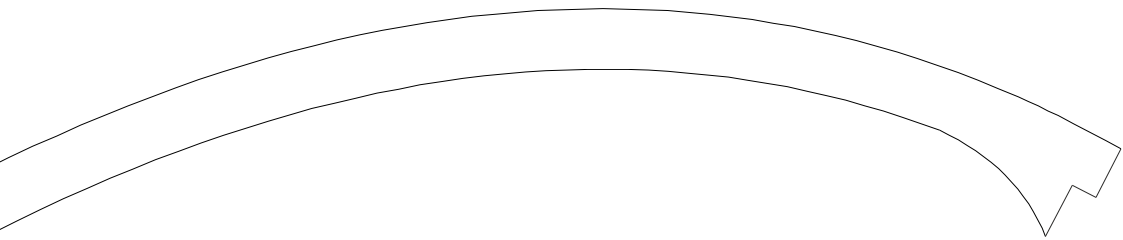





12

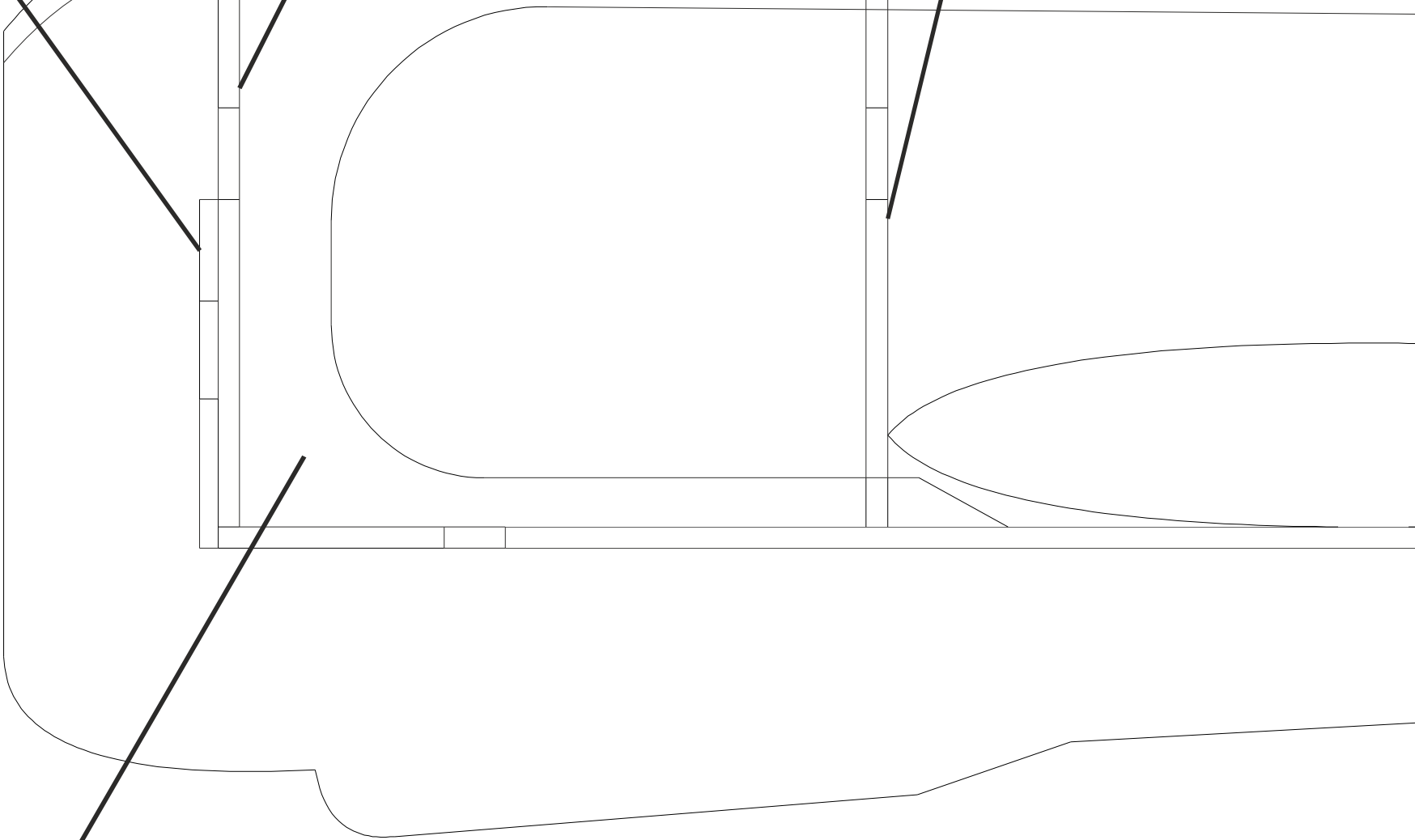

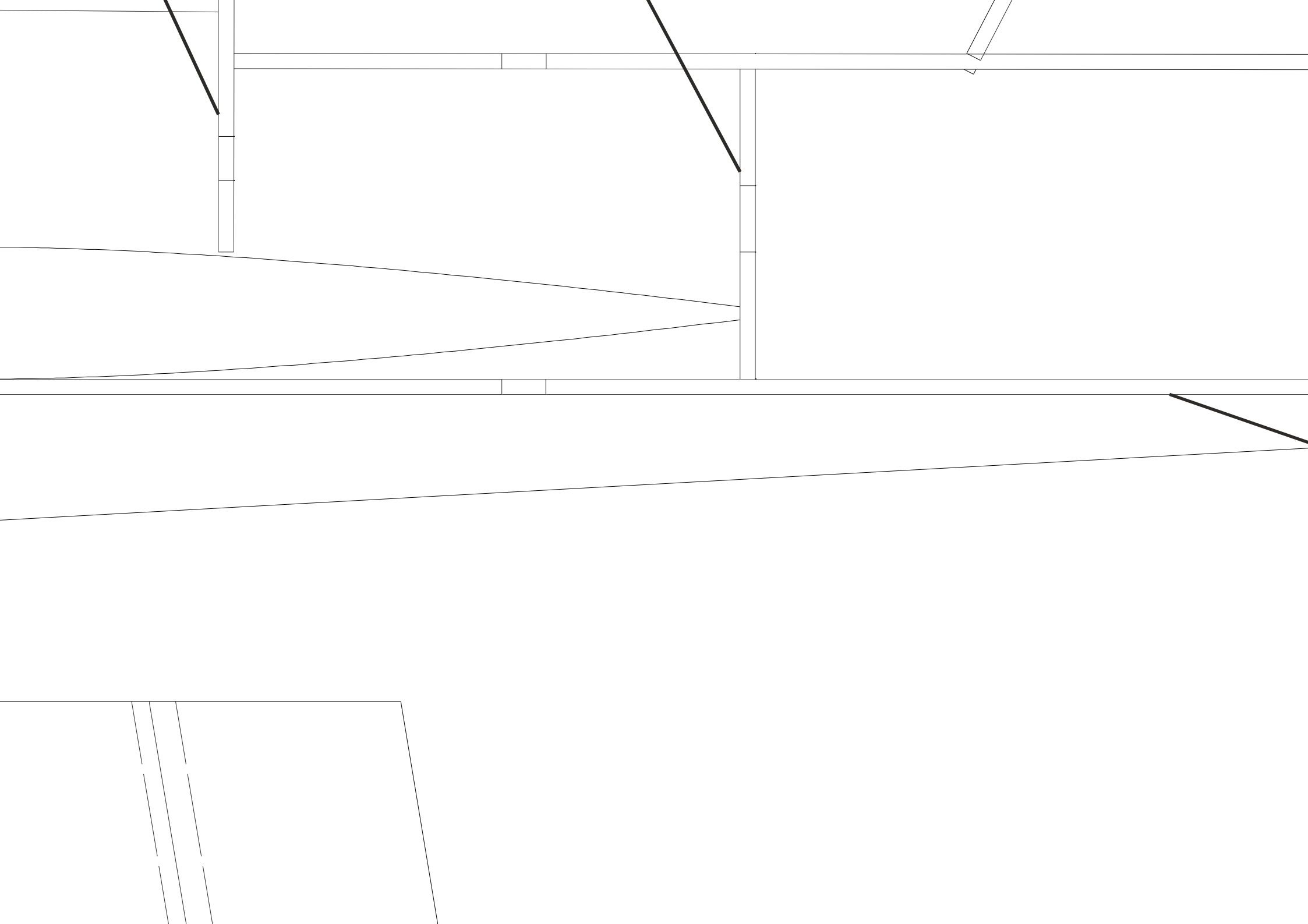

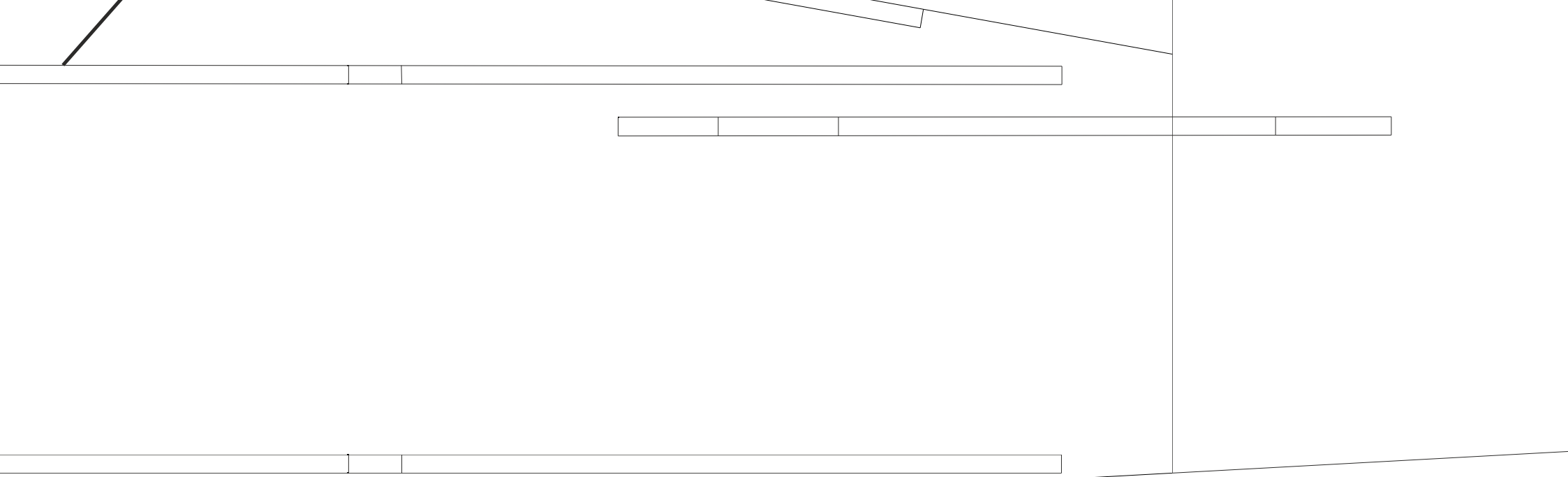

11

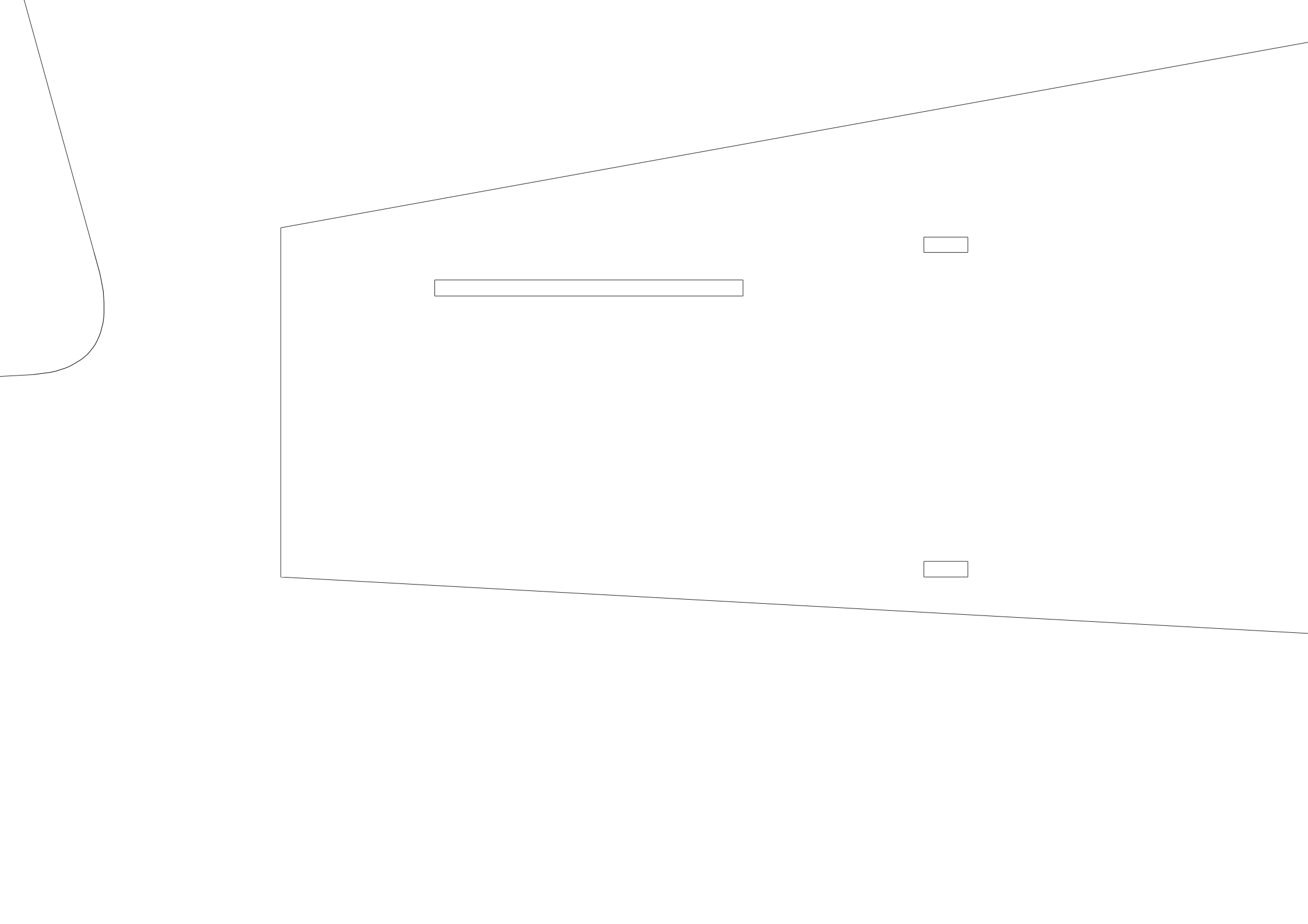



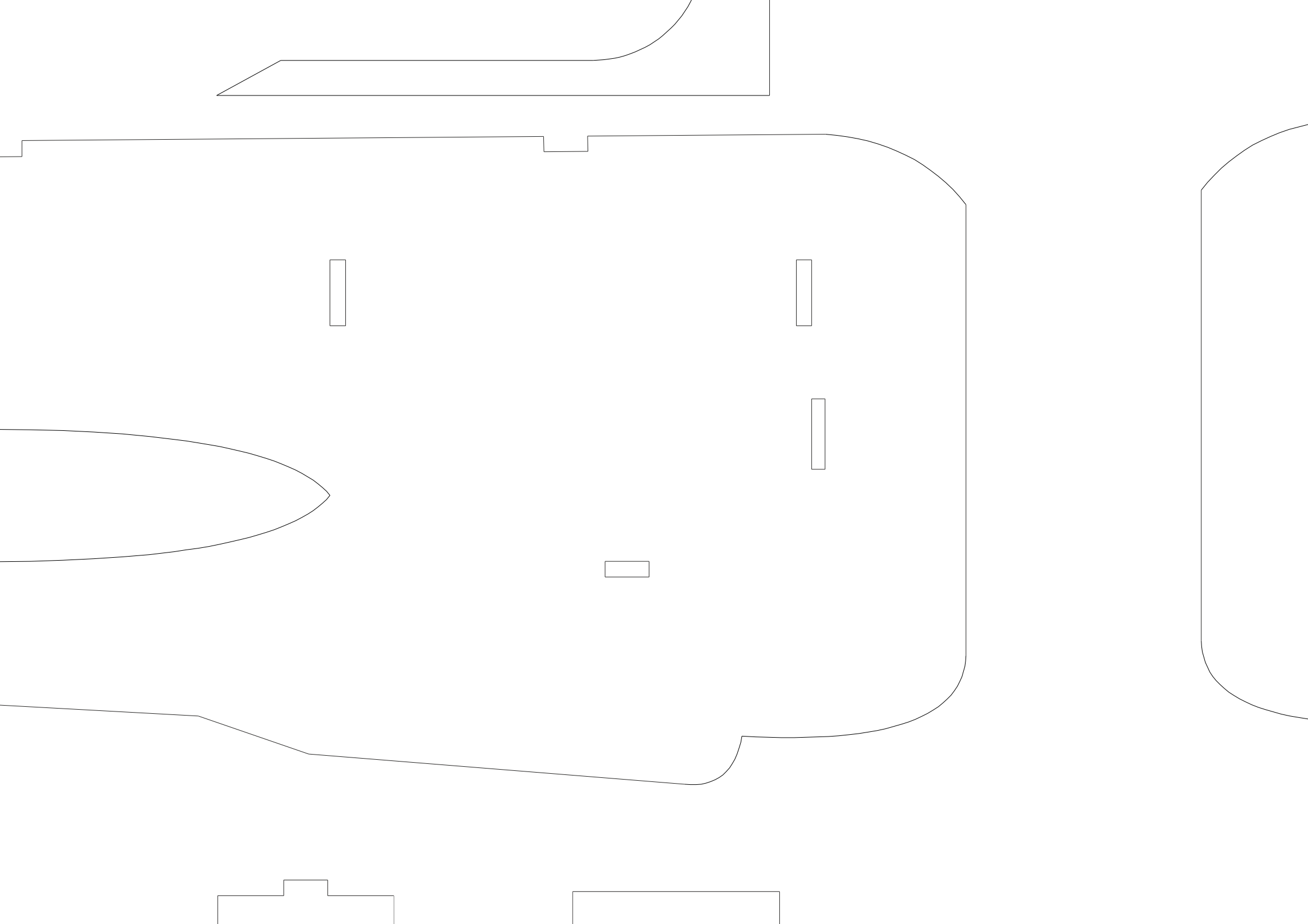

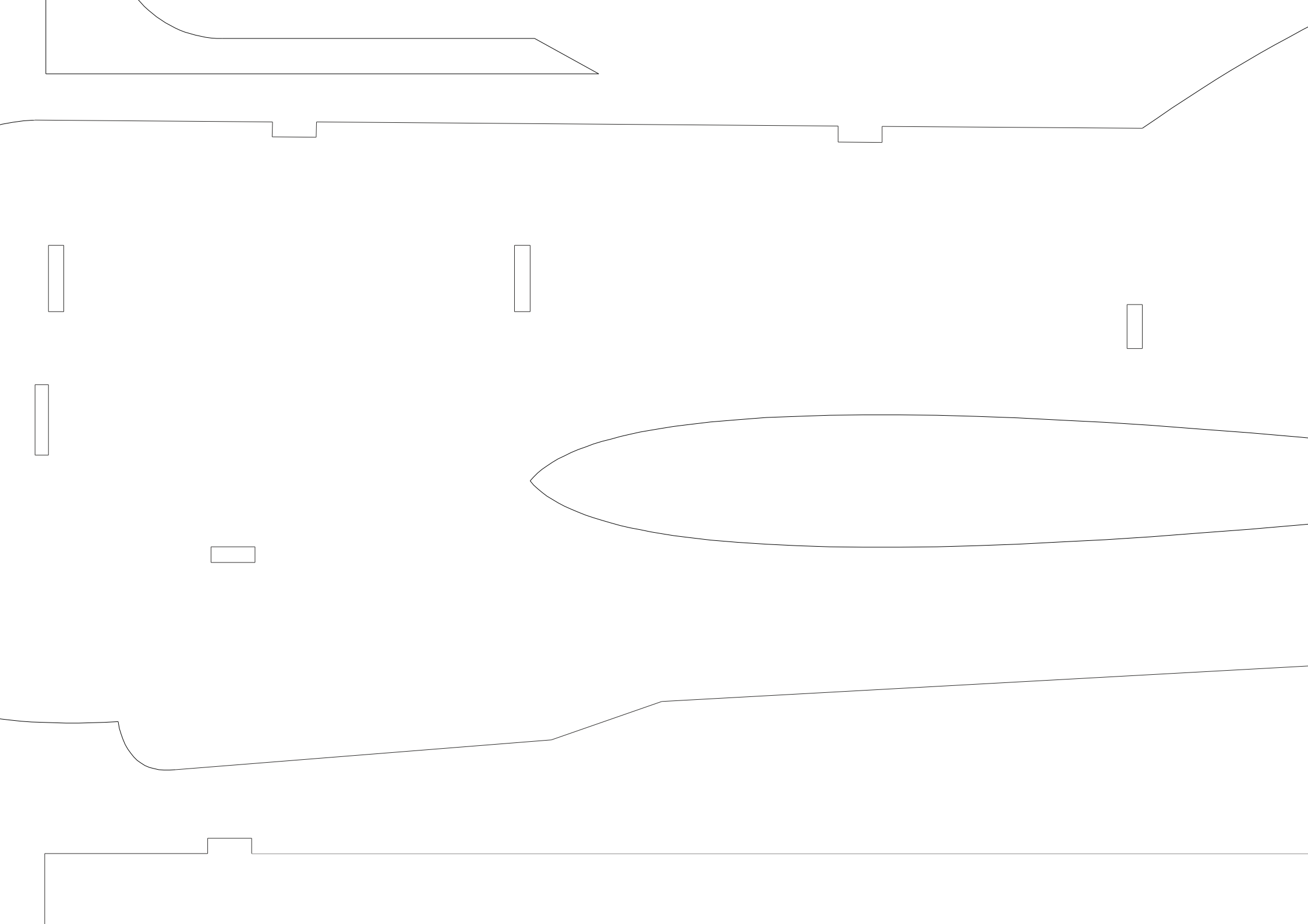



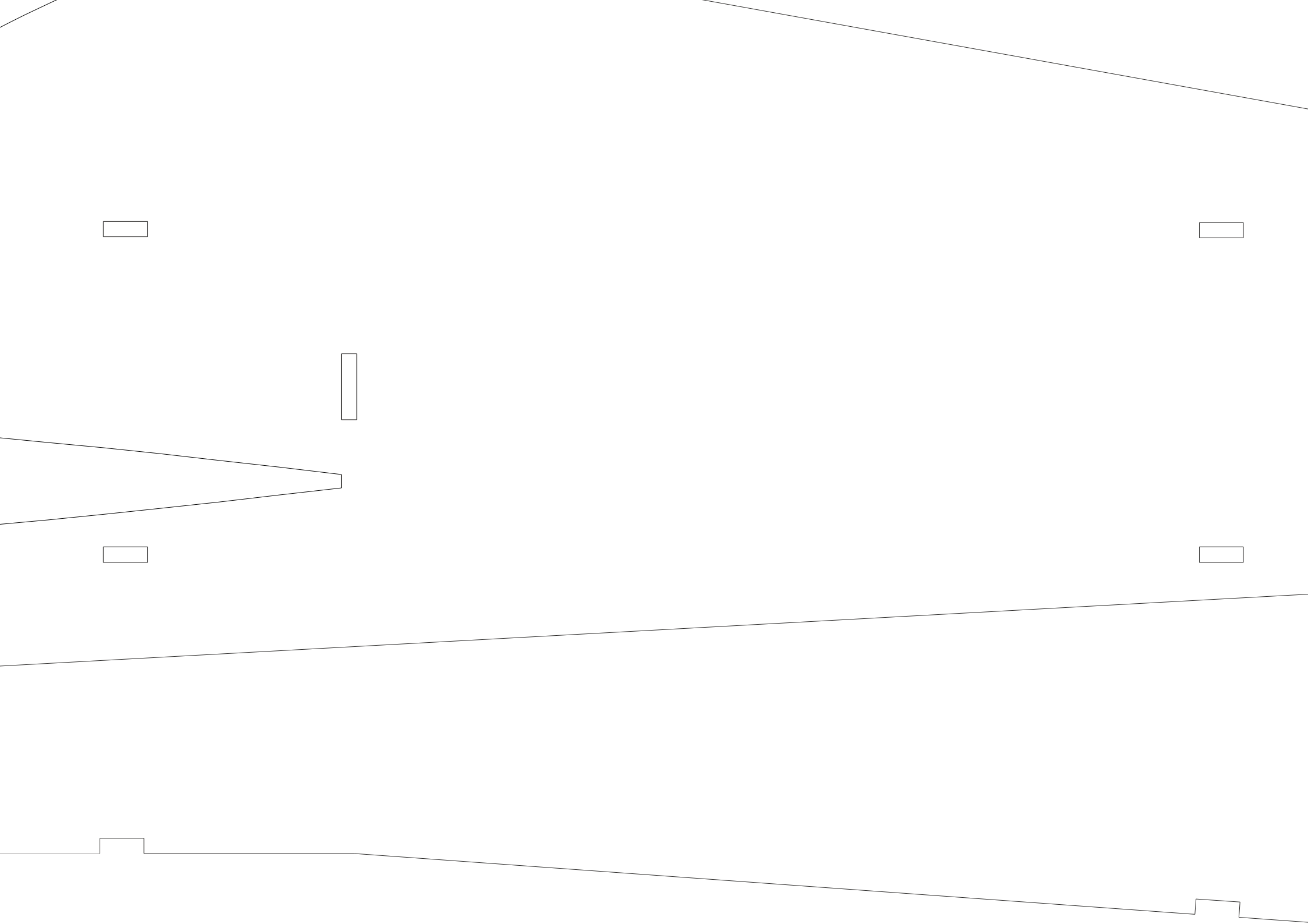

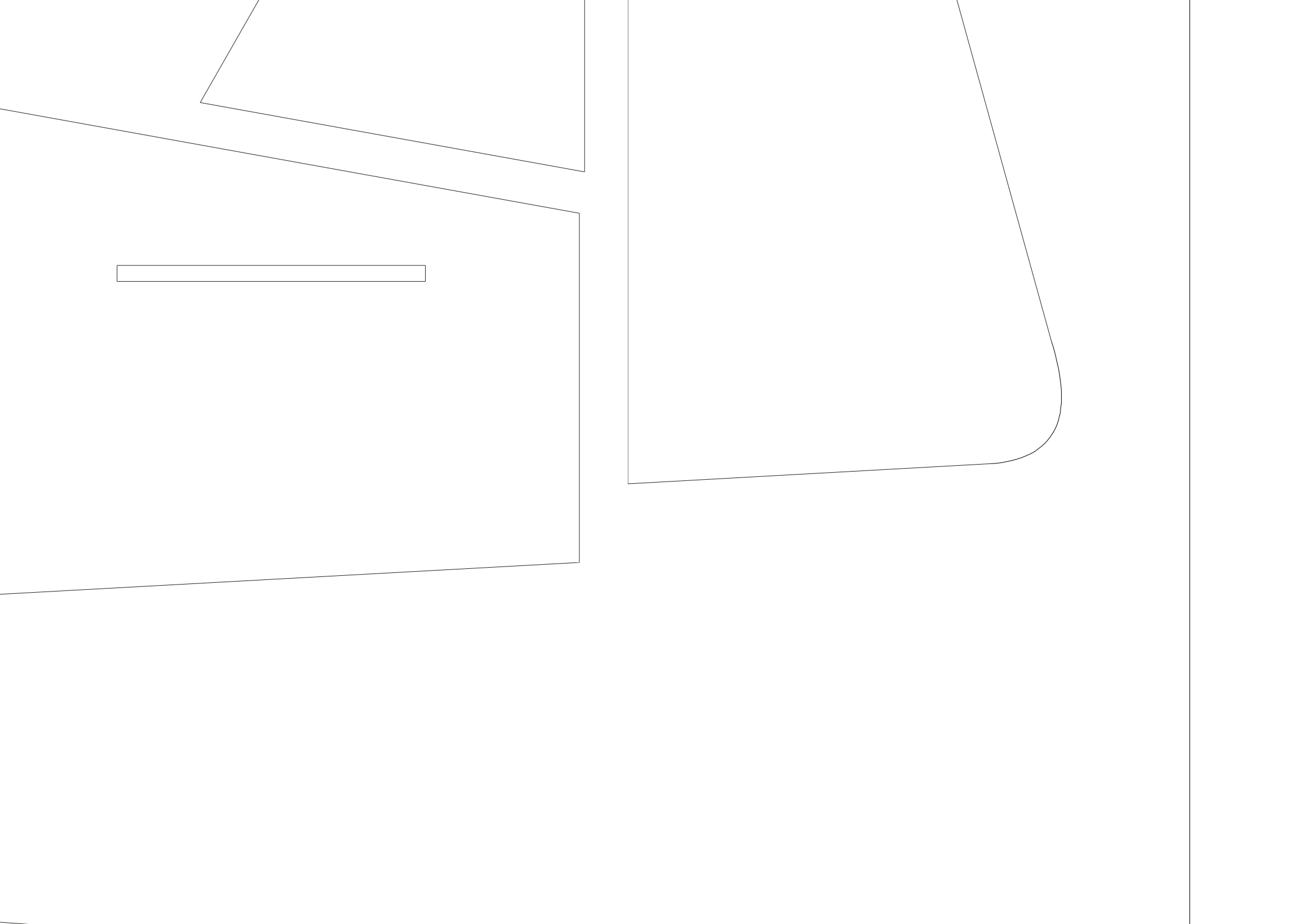



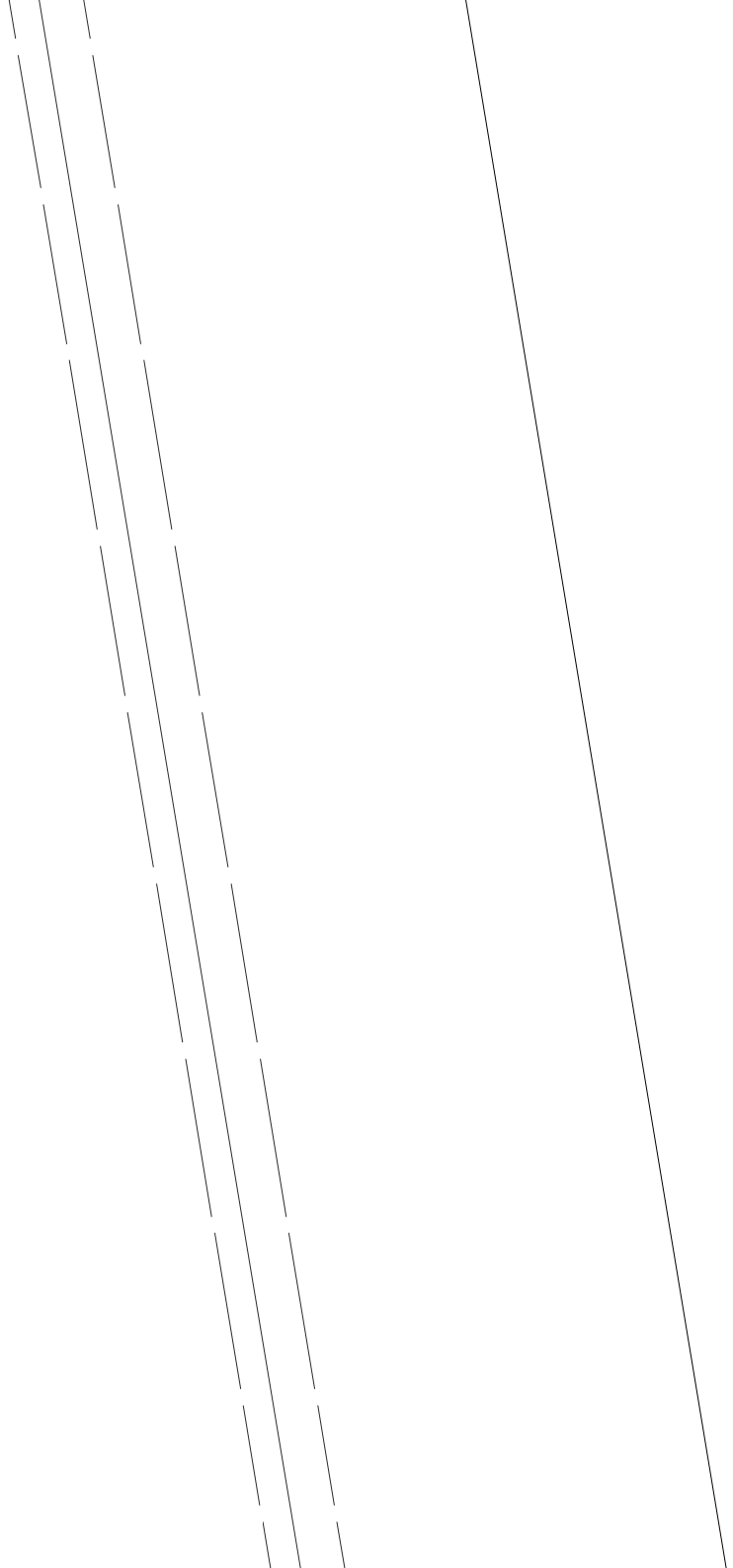





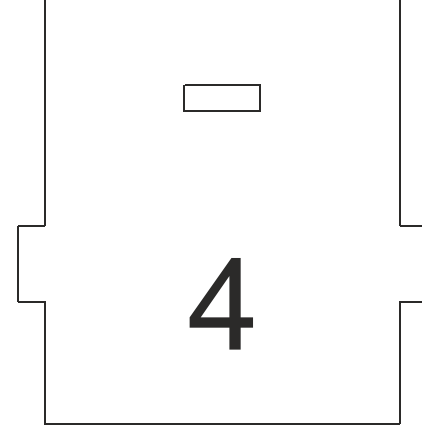
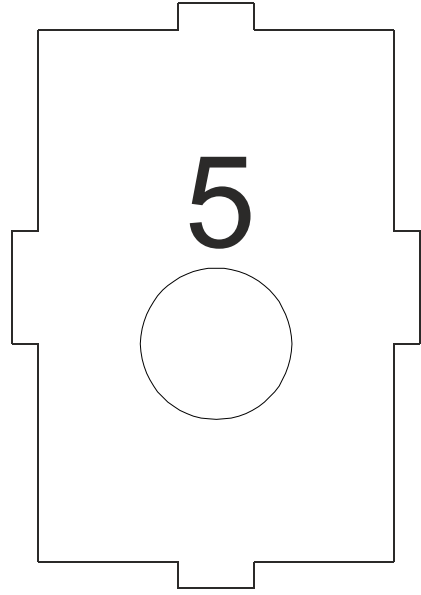
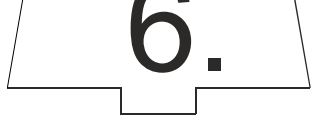

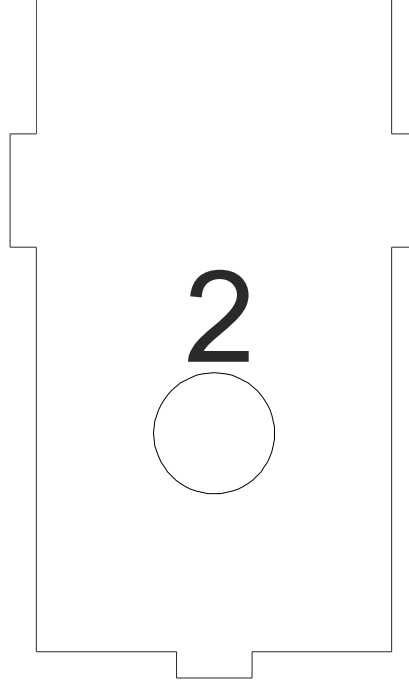
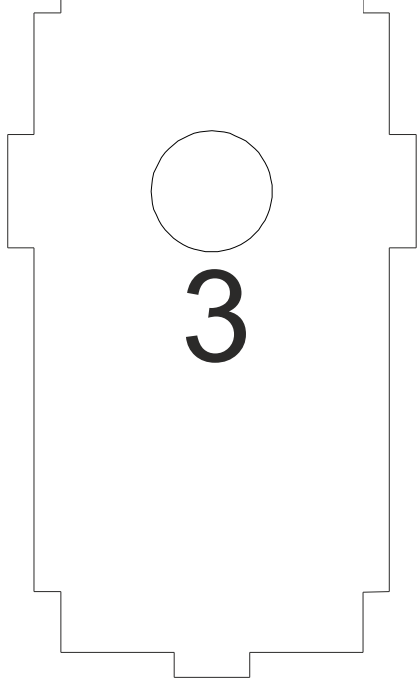





Усилите

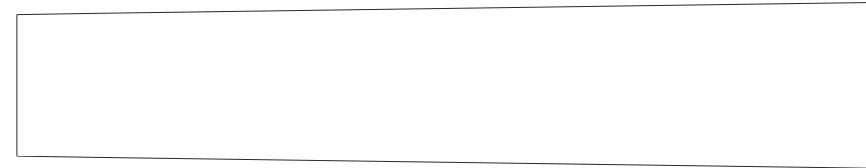



Лонжерон крыла

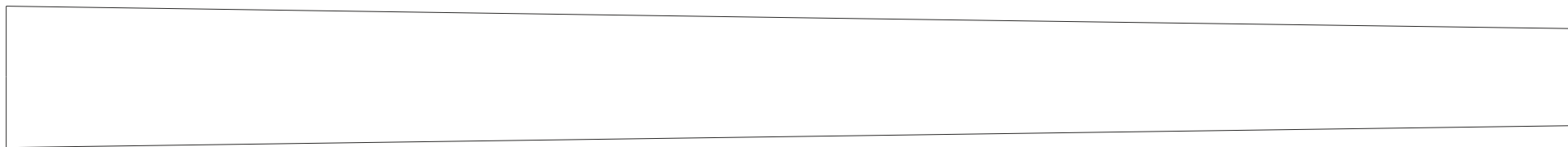

Лонжерон крыла (2 шт.)



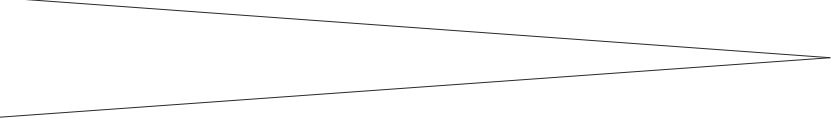

(2 шт.)

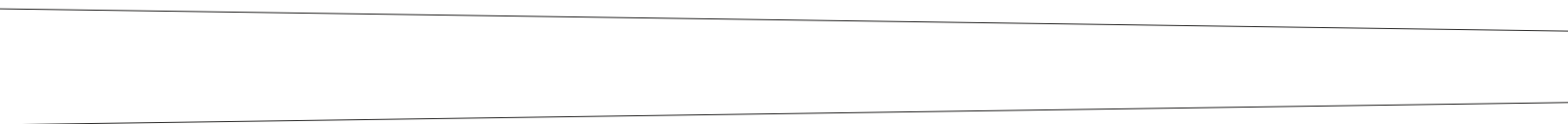



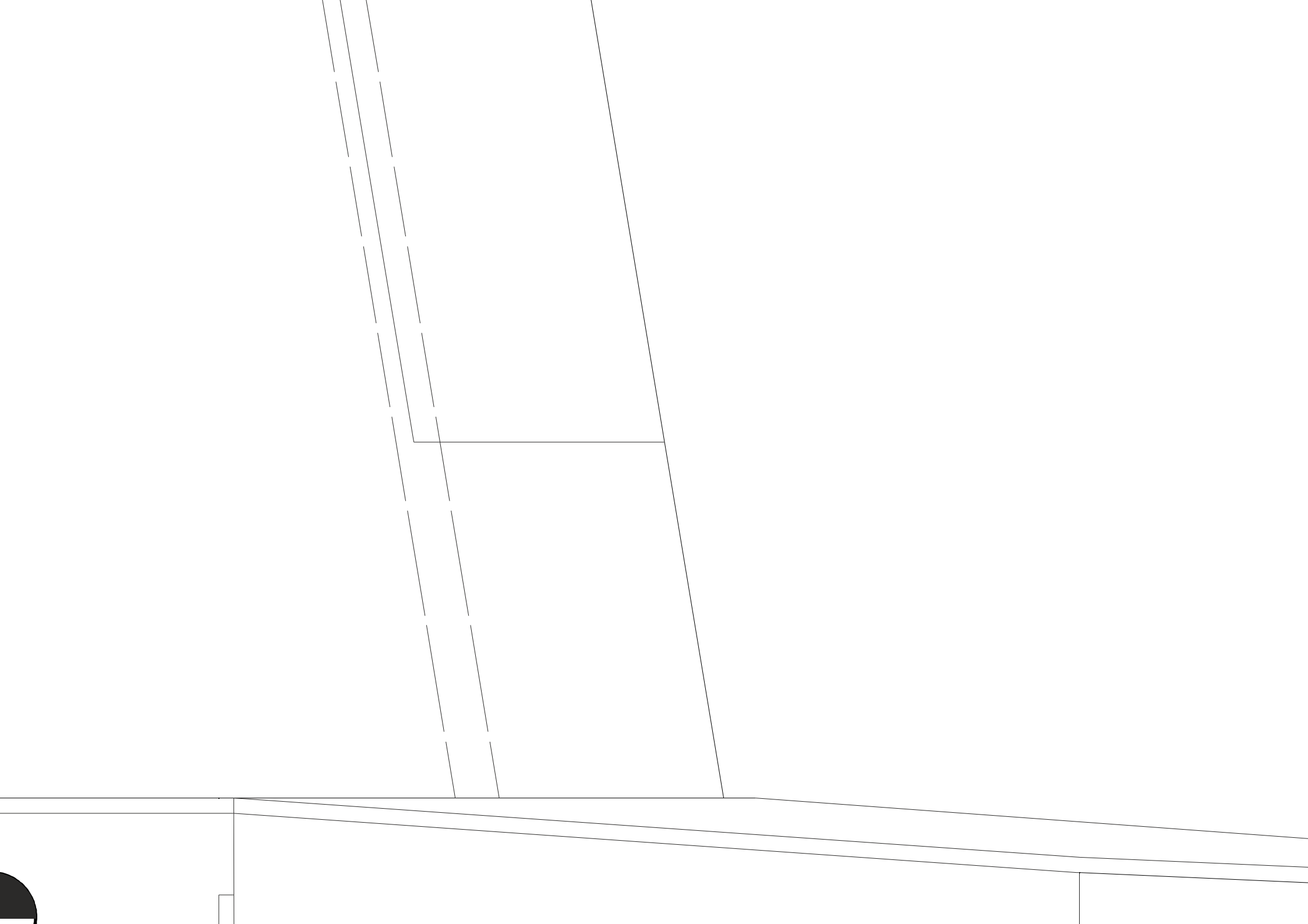

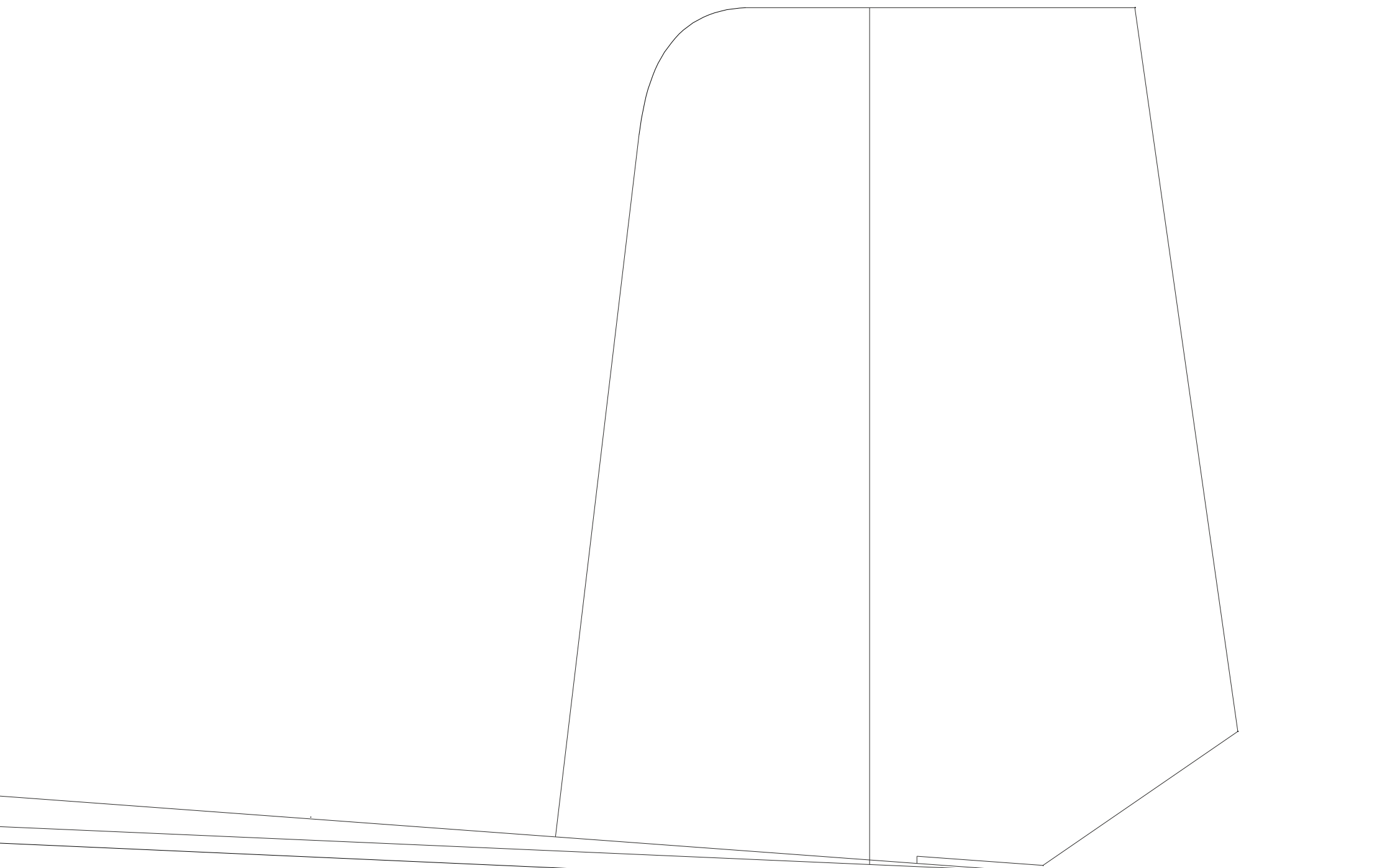







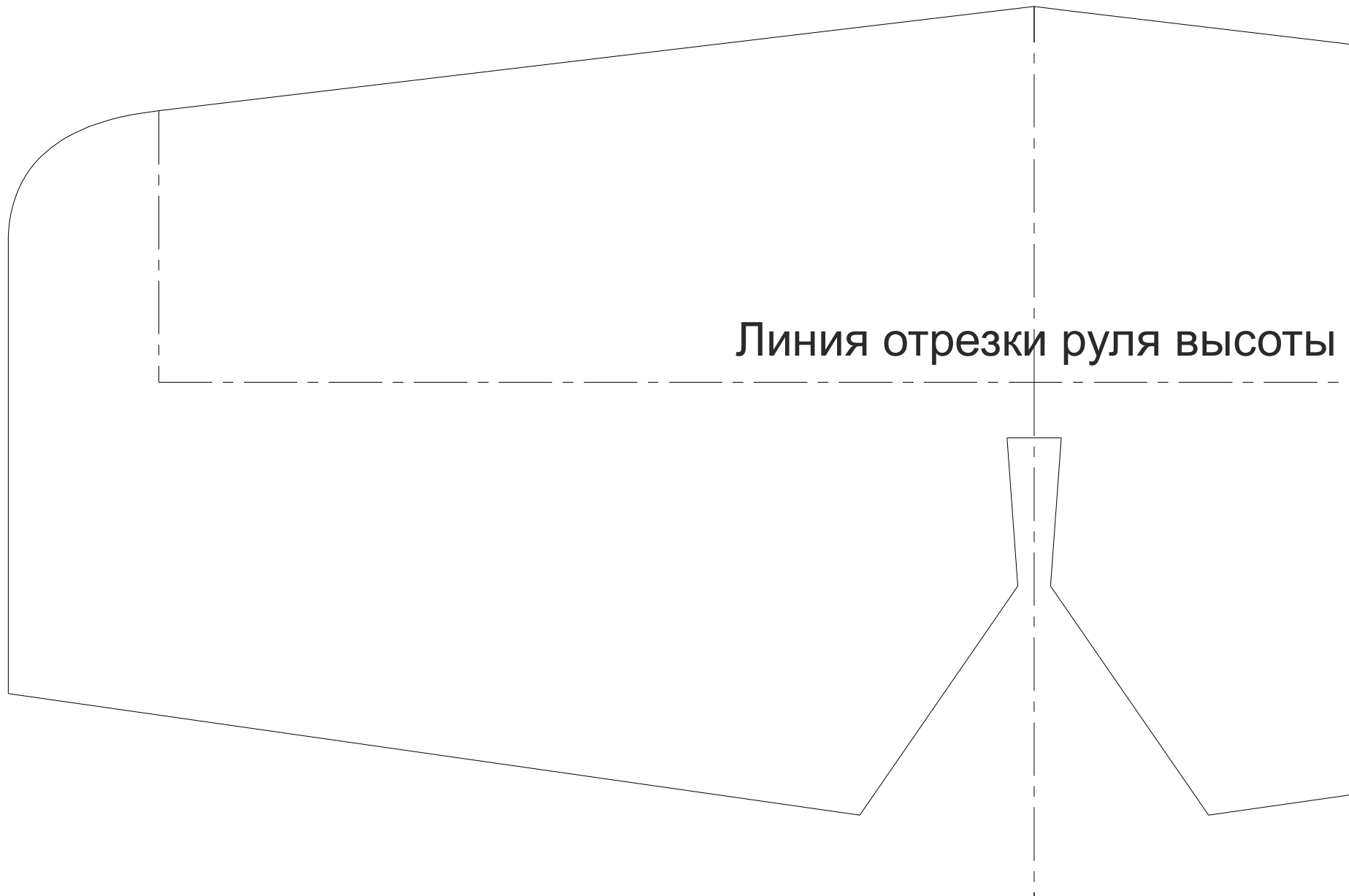

Линия отрезки руля высоты

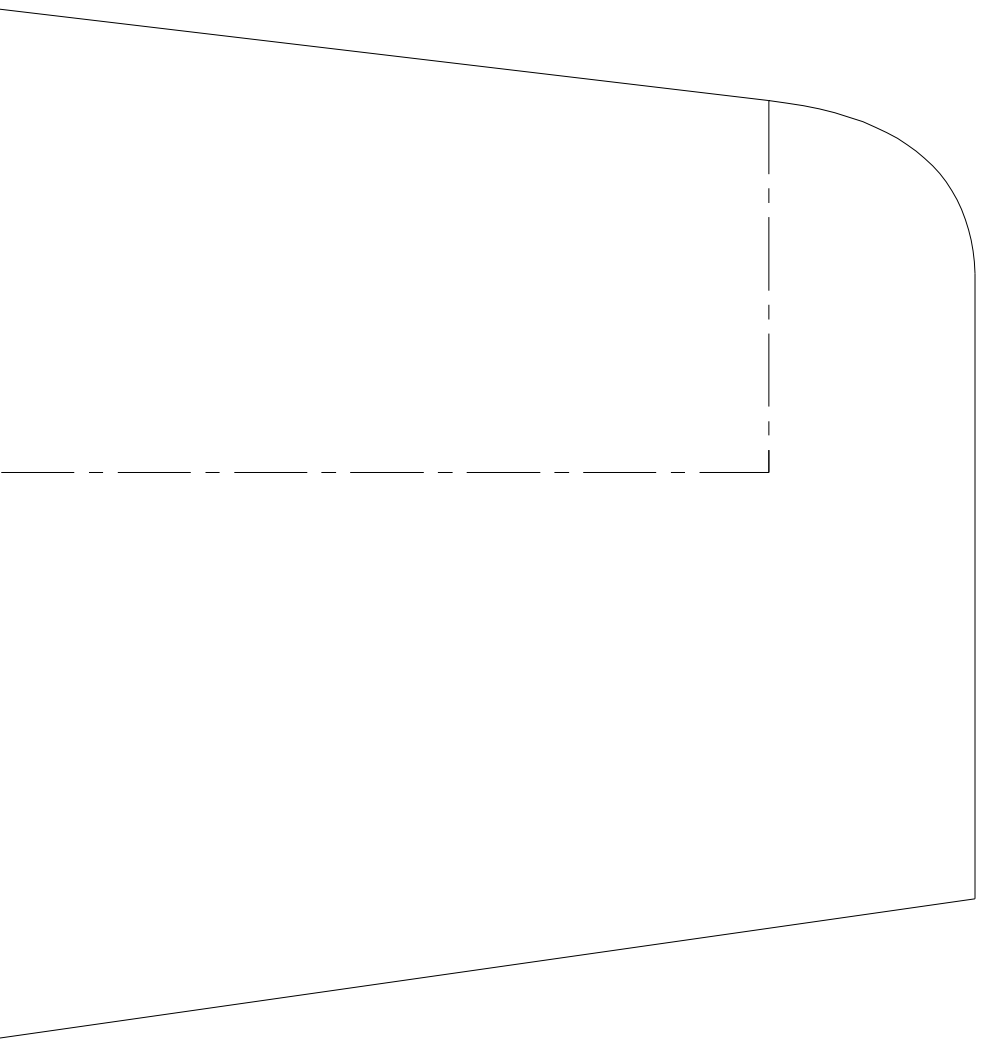

# Обшивка крыла (

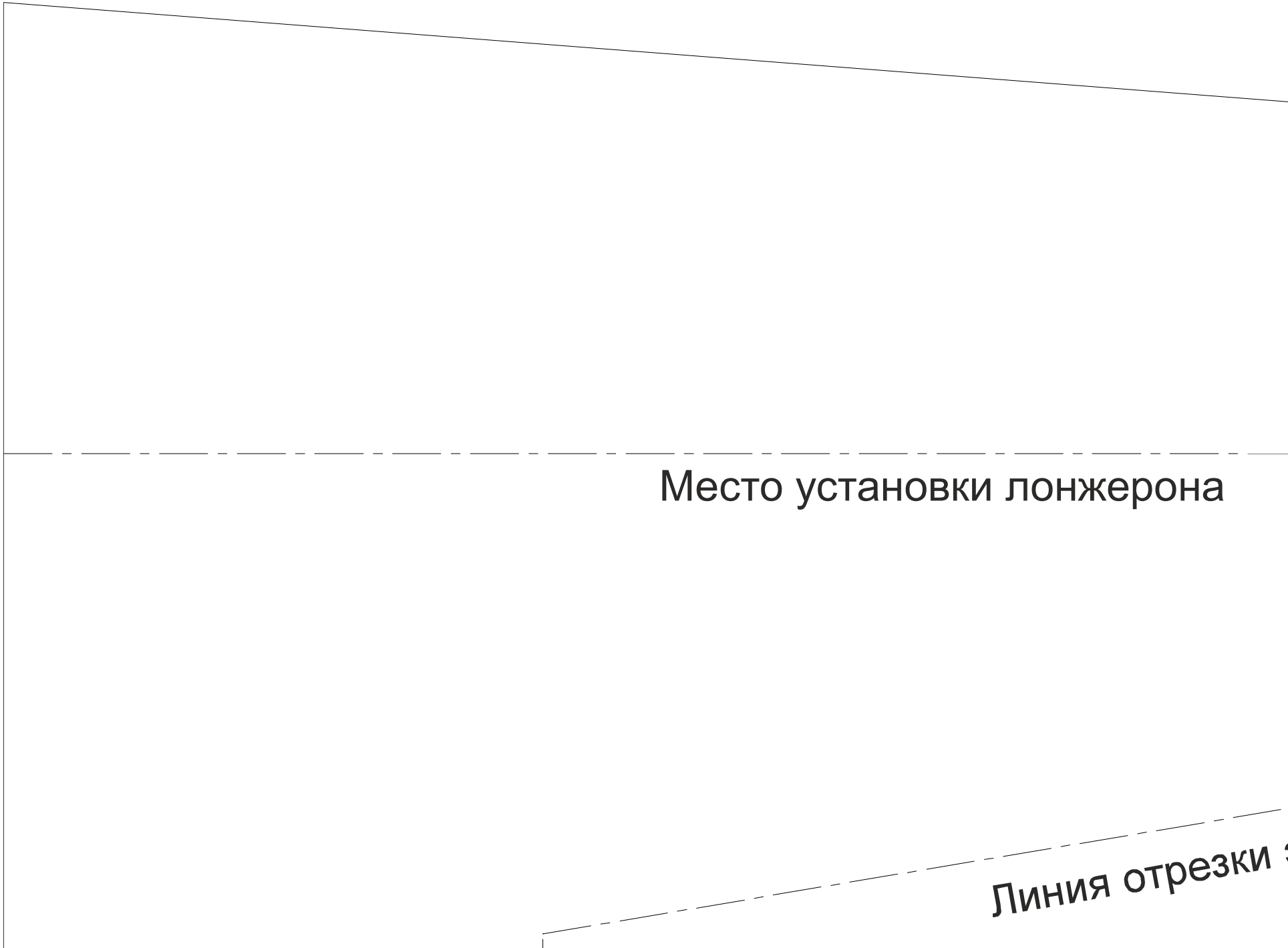

Место установки лонжерона

Линия отрезки

4 шт.)

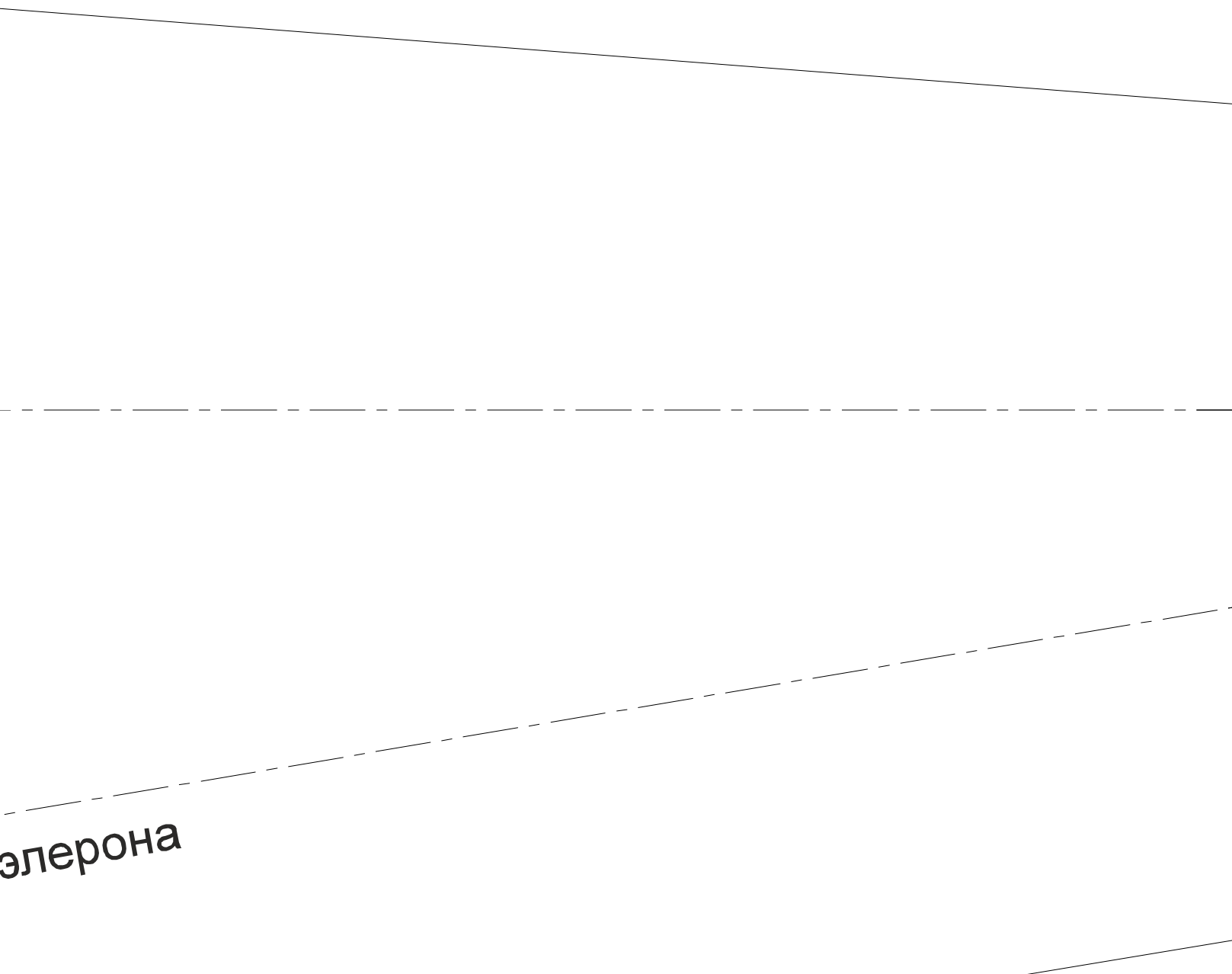

элерона



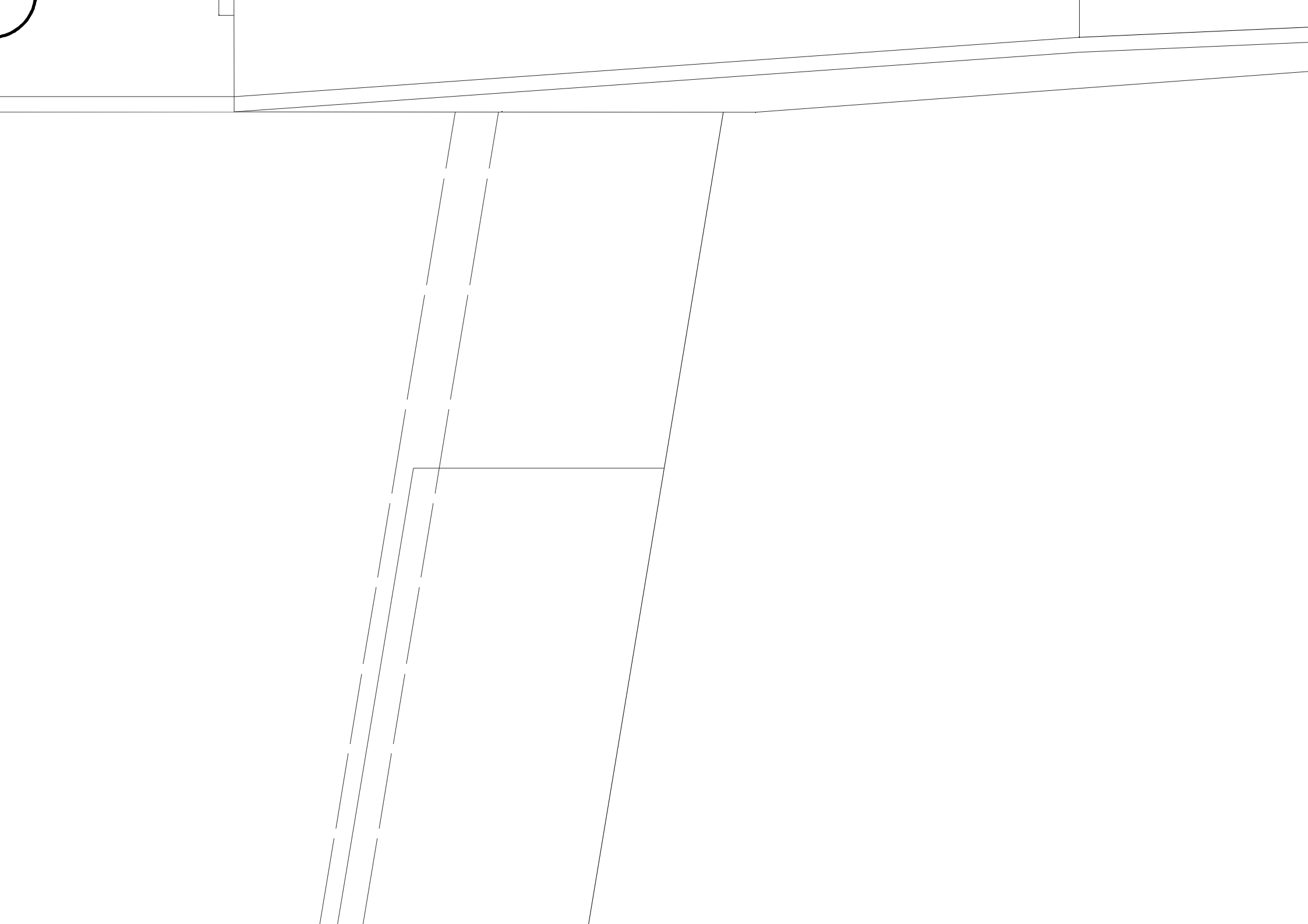

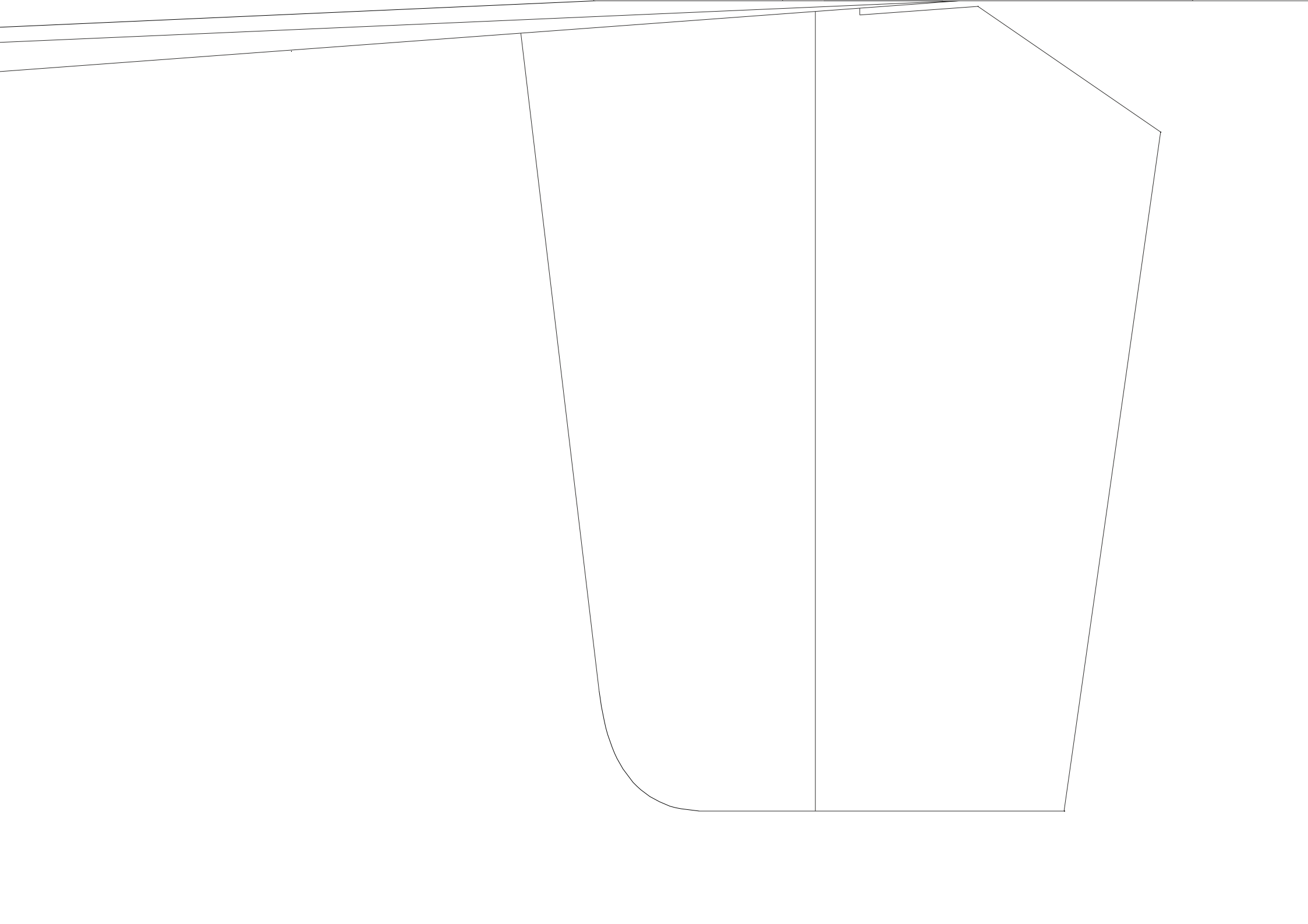

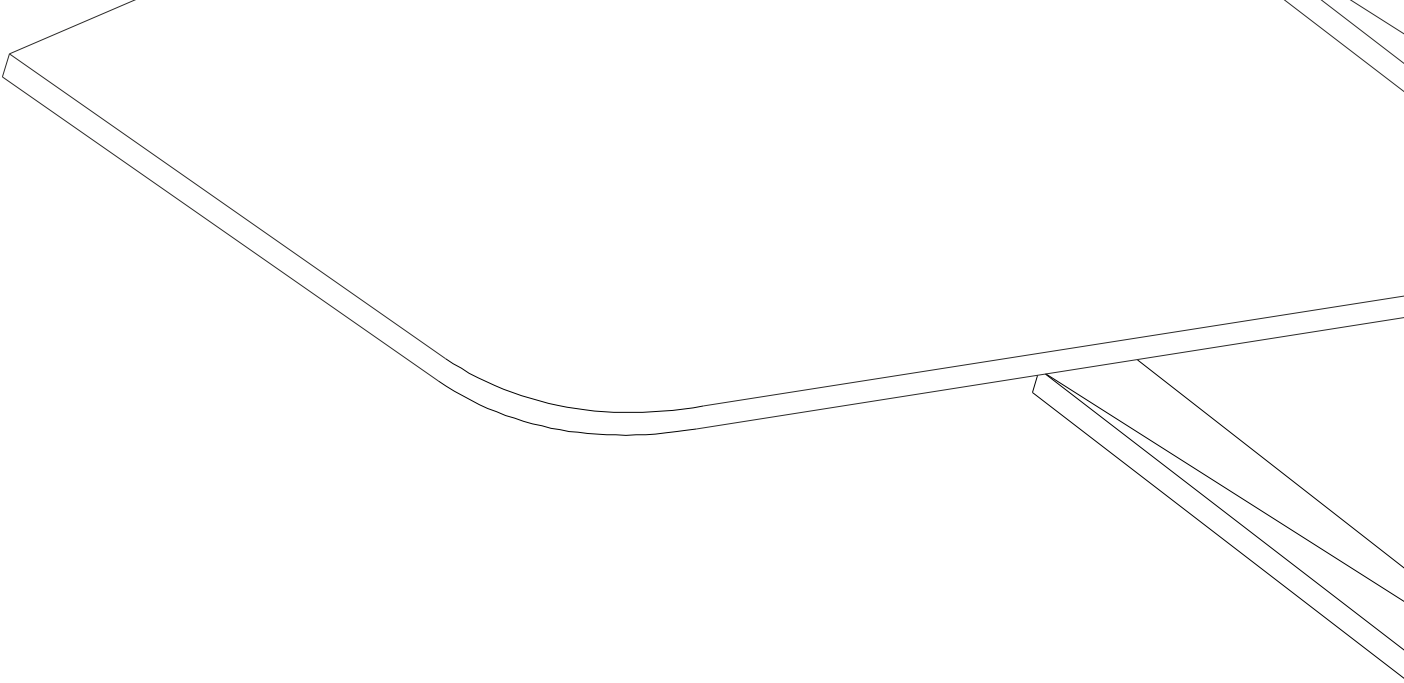



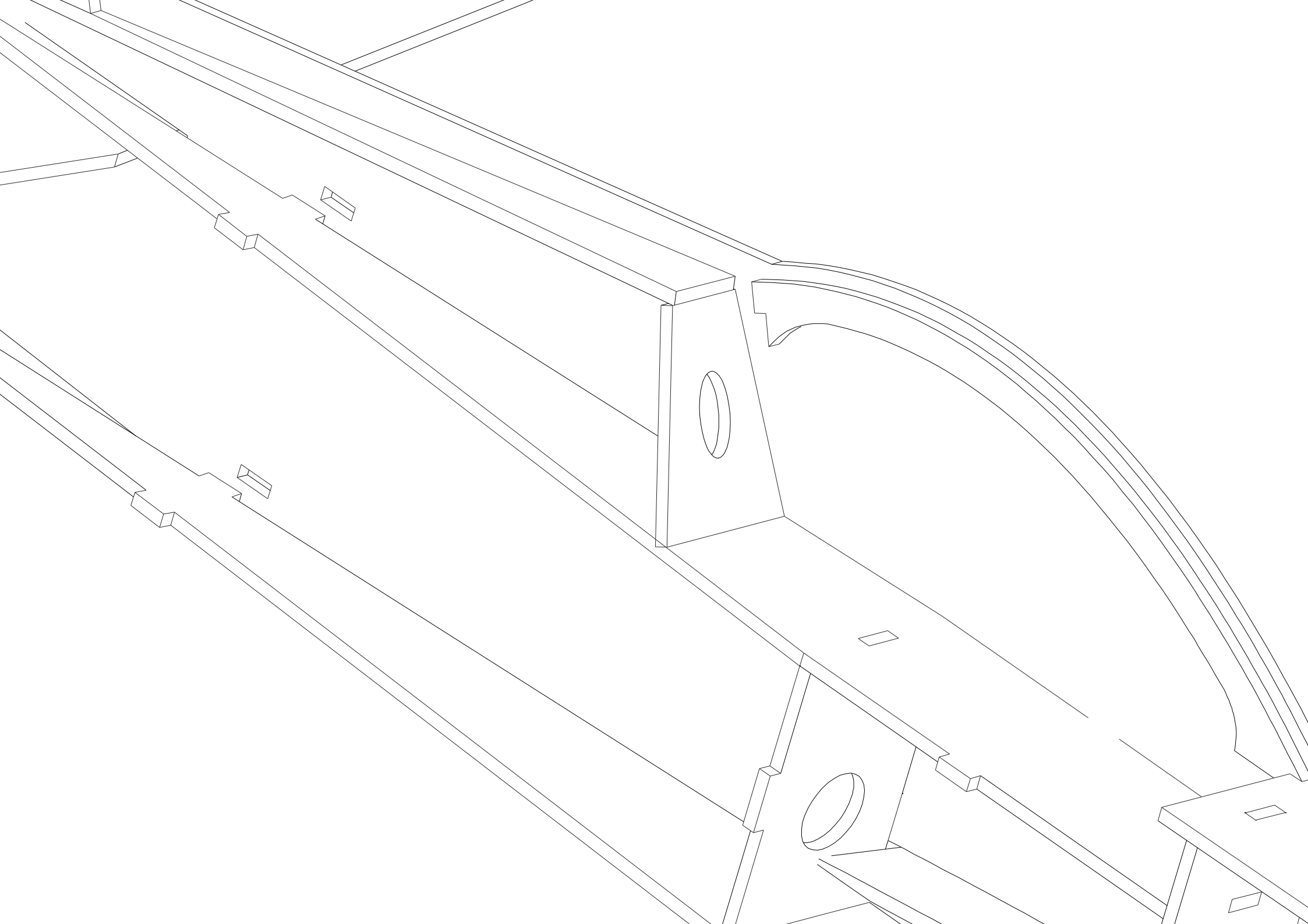



Подробнук  
получить пр  
Вопне во

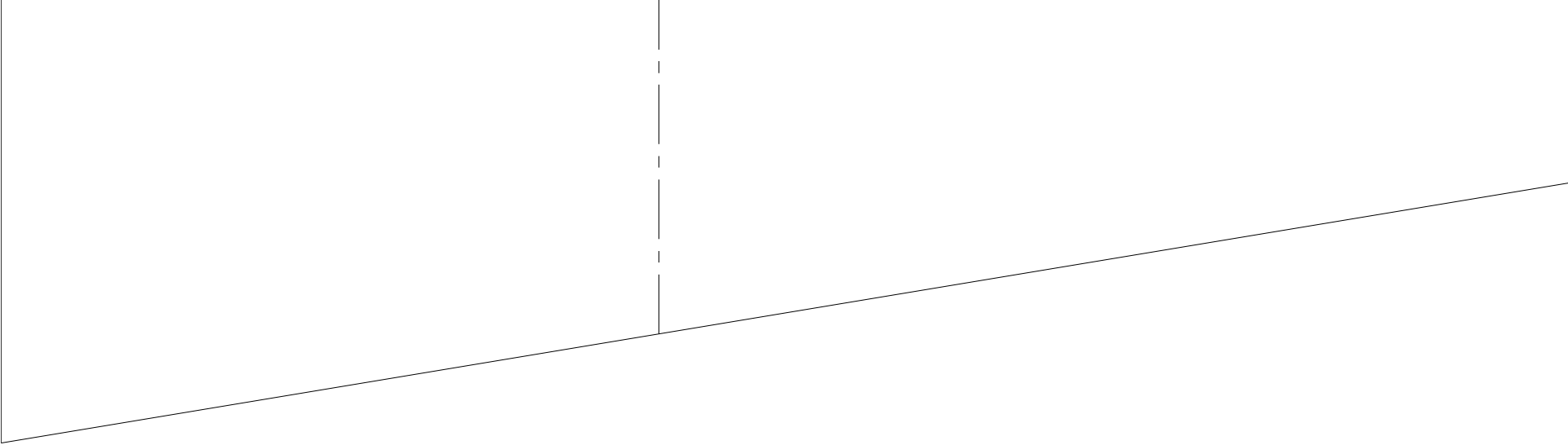

о информацию и консультации по сборке можно  
ойдя по ссылкам, указанным в угловом штампе.  
зможно, что SU-26 понравится Вам и у Вас.



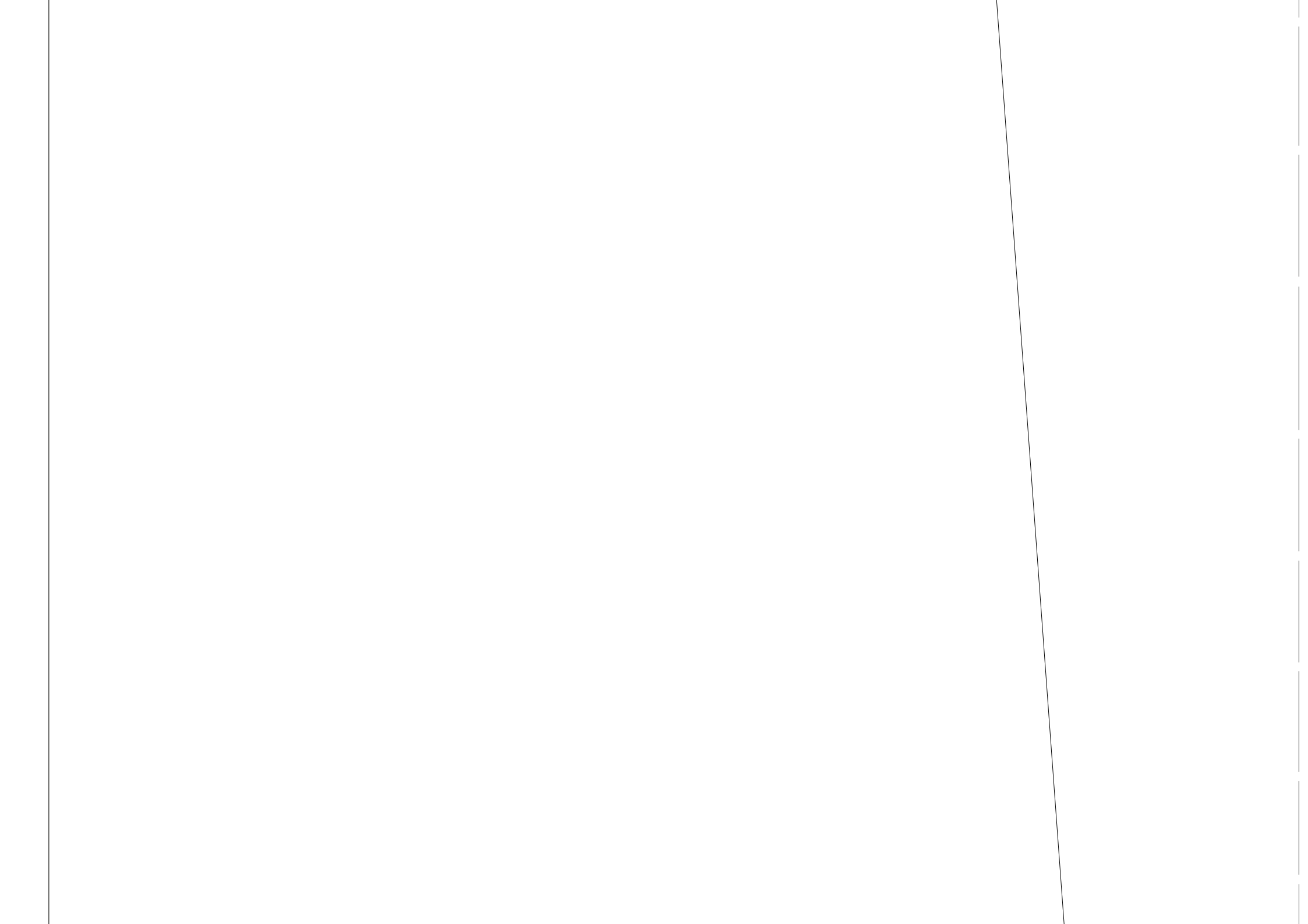

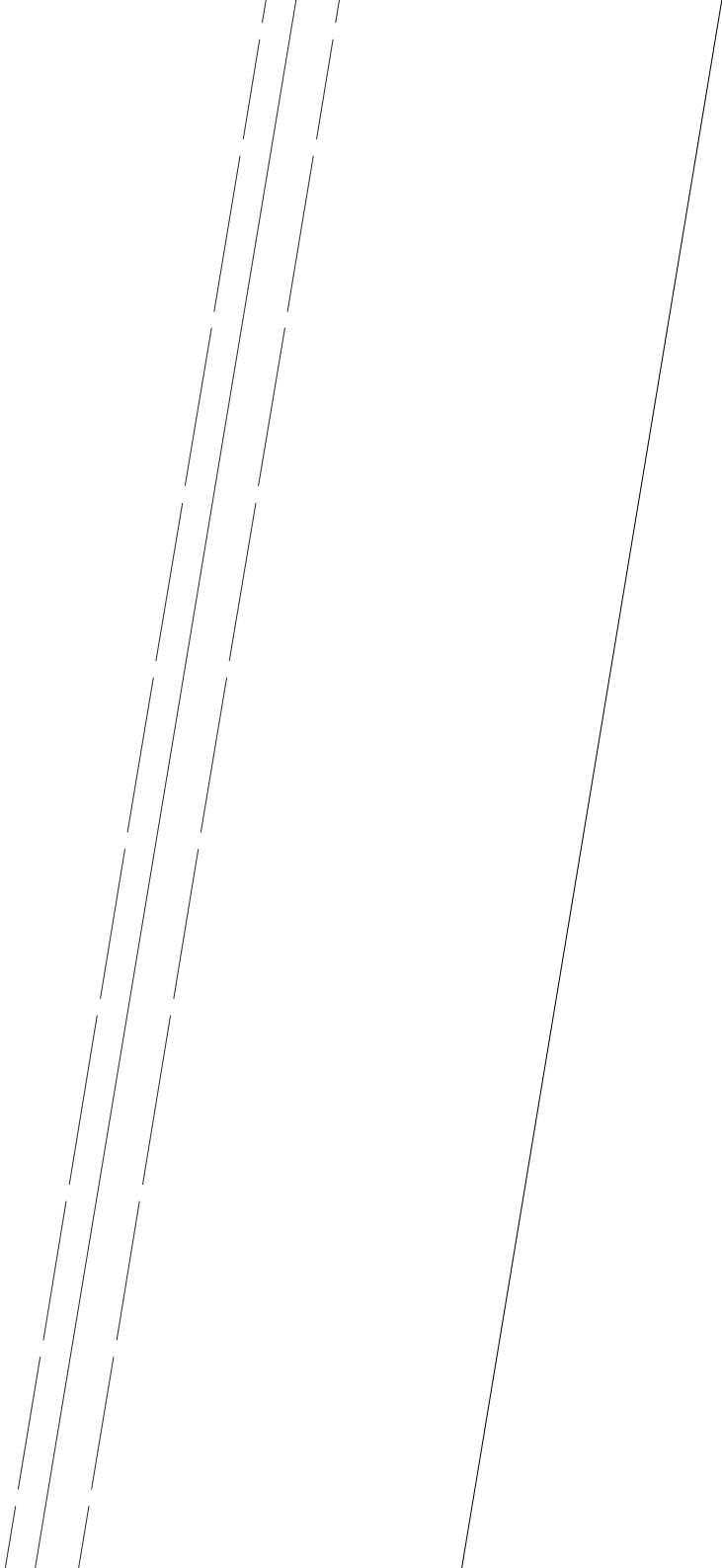







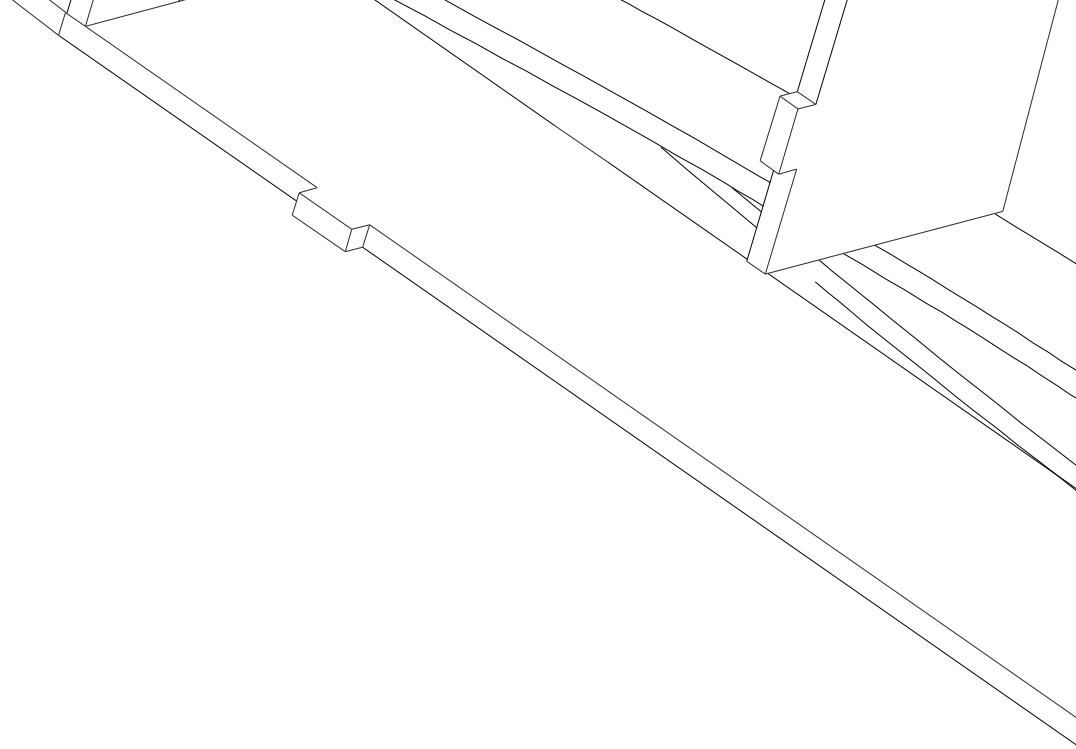

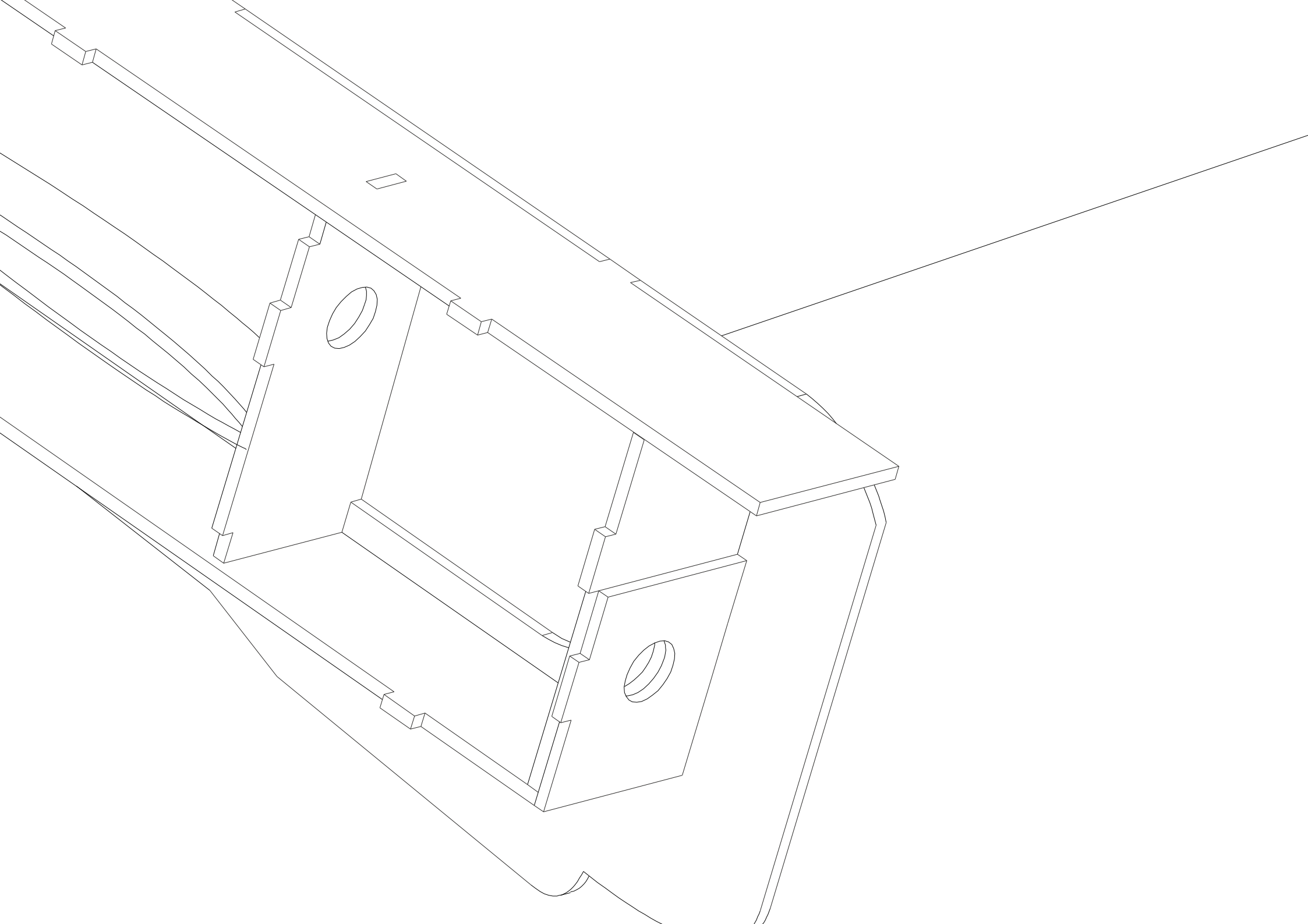

появится ж  
это, перечи  
Яндекс де

## Recommended

Engine	-	TURNIGY D
Controller	-	TURNIGY P
Servo	-	HKSCM9-6
Propeller	-	Master Airs
Battery	-	ZIPPY Comp
Control equipment	-	4 - 5 cha

...можете, но все же направител вам, и у вас  
...елание меня отблагодарить. Вы можете сделать  
...слив добровольное пожертвование на  
**СЧЕТЫ: 410012624757995**

### Equipment:

D2830-11 1000kw  
Plush 25amp Speed Controller  
digital micro servo (4 pcs.)  
Screw S-2 (Scimitar) 9x6  
Batteries 1000-1300mAh 3S 25C Lipo  
Channels

### Specifications:

Wing span	-	937 mm
Wing area	-	18.4 <sup>2</sup> dm
Fuselage length (front of cowl to end of rudder)	-	848 mm
Weight (ready to fly)	-	370-430 g
Wing loading	-	20...23 g/dm <sup>2</sup>



# SU-26 foam

Sheet  
1 of 2

Designed by: **Dmitry Pushkarev**

email: **dmi5462@yandex.ru**

Building notes & photos: <http://rc-flyers.ucoz.ru/forum/12-191-1>  
[http://rc-flyers.ucoz.ru/photo/su\\_26\\_iz\\_potolochki\\_v\\_kartinkakh/37](http://rc-flyers.ucoz.ru/photo/su_26_iz_potolochki_v_kartinkakh/37)

For individual use only not for commercial

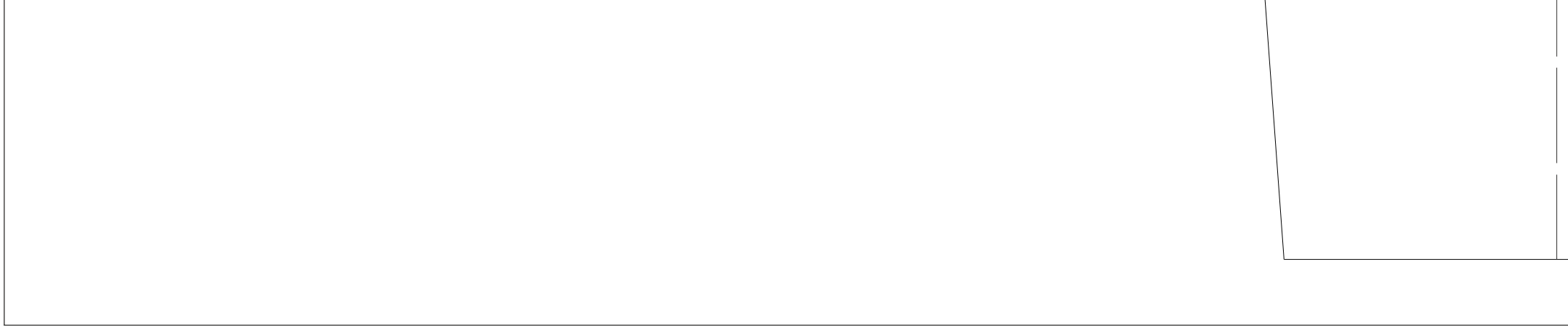

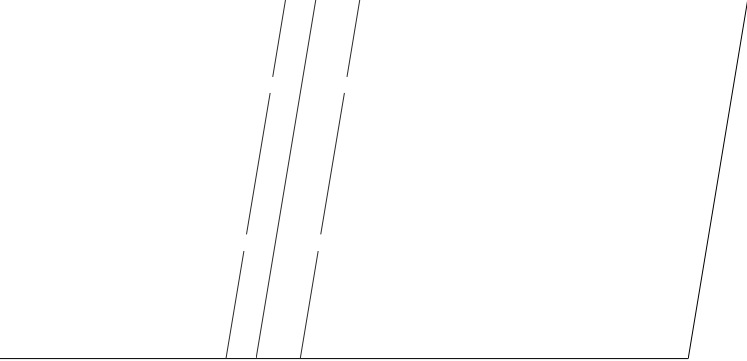









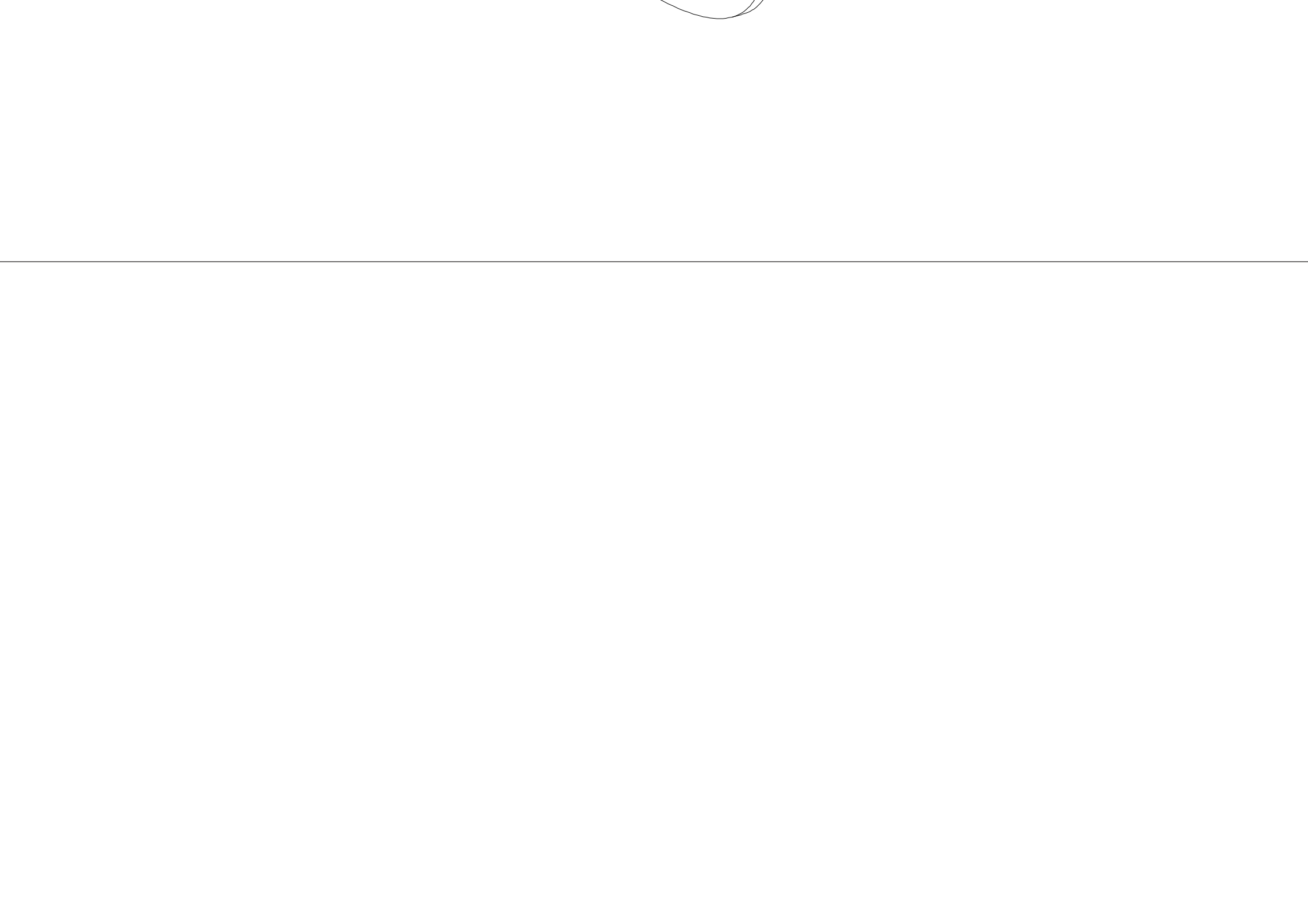

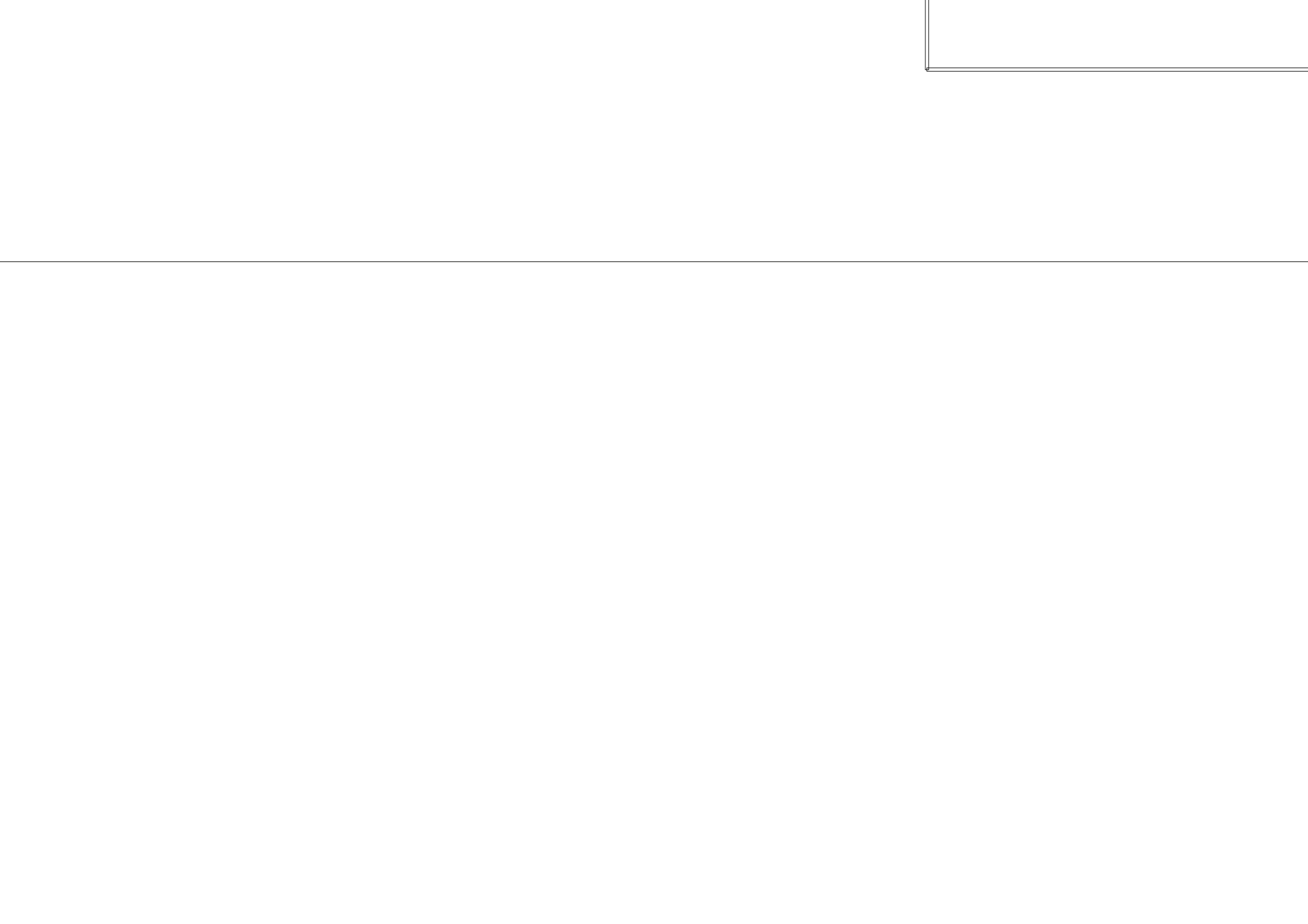

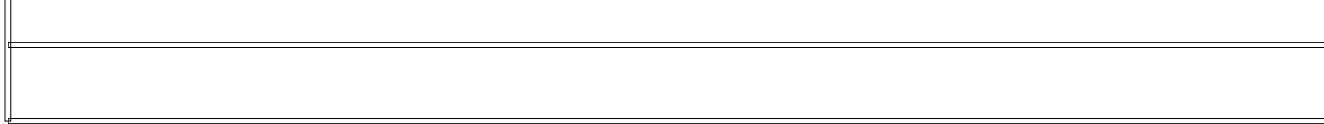

For individual use only, not for commercial

Вы можете использовать и распространять эти материалы на любом носителе, и не можете назначать цену либо получать деньги за использование и распространение этих материалов.